

REV/DESCRIPTION/ECD NO.	DATE
F INITIAL CAD DRAWING RELEASE	3/4/04
G CHANGE HEATSHRINK AND STRIP LENGTH	3/24/04

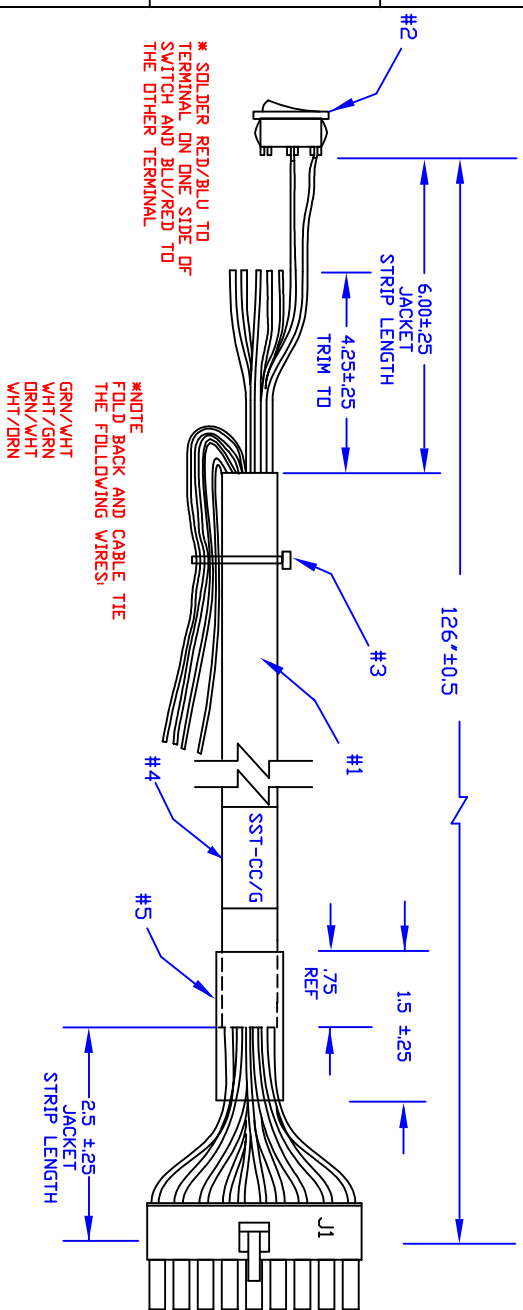

NOTES:
 ALL CABLES TO BE INDIVIDUALLY BAGGED WITH PIN-OUT INSERT AND LABELED AS FOLLOWS:
 SST-CC/REV
 [CURRENT REV]

BILL OF MATERIALS

6	1	JUMPER, 24 AWG, BLK, 1 1/2'	BELDEN/9984-010100 DR EQ
5	1	HEATSHRINK, 3/4" X 1 1/2"	RAYCHEM/VERSAFIT-3/4-0
4	1	CABLE MARKING, WRAP TYPE 1 X 3/8" WHITE	BRADY/DAT-85-292-X DR PANDUIT/PDL-249-1
3	1	CABLE TIE, 4", BLK	RICHCO/WIT-18R-3 DR EQ
2	1	SWITCH, SPDT, ROCKER	E-Switch/RA1066AFH
1	16	TERMINAL, SOCKET, 28-28 AWG	MOLEX/34-00-0046
J1-A	16	TERMINAL, SOCKET, 28-28 AWG	MOLEX/39-01-2180
J1	1	HOUSING, MINIFIT 18, RECP	MFG/PART NUMBER

J1 ASSIGNMENTS

SIGNAL	COLOR	COLOR	SIGNAL
+LIMIT	GRN/RED	10 1	RED/GRN
ENC A	DRN/RED	11 2	RED/DRN
ENC B	BRN/RED	12 3	RED/BRN
ENC 1	WHT/DRN	13 4	DRN/WHT
+5V In	NC	14 5	BLK JUMPER *
MODE	WHT/GRY	15 6	NC
ANALOG +	WHT/BLU	16 7	BLU/WHT
READY~	GRY/WHT	17 8	RED/BLU
STEP	GRN/WHT	18 9	BRN/WHT

WIRE END VIEW

TOLERANCES UNLESS OTHERWISE SPECIFIED:		DATE	SCALE	DRAWN BY	MATERIAL	FINISH	DESCRIPTION	DWG NO.	REV.
ANGULAR ± 1°	LINEAR ± .020	3/4/04	NONE	TDT	see BDM	N/A	CABLE, SST-1500 TD CUSTOM CONTROLLER	SST-CC	G

Teknic, Inc.