

# Teknic Hudson<sup>®</sup>

## NEMA 34

- All dimensions are in inch [mm] unless otherwise noted.
- Sheet Scale 1:1
- Undimensioned features are per 3D file for model of interest for reference use.
- Unless otherwise specified, untoleranced dimensions are nonbasic and default to:
  - X.XX: ± .010" [0.25mm]
  - X.XXX: ± .005" [0.125mm]
  - Angles: ± 1°

Model Number	L
M-341 _ _ _ _	2.802 [71.18]
M-342 _ _ _ _	3.543 [90.00]
M-343 _ _ _ _	4.291 [109.00]
M-344 _ _ _ _	5.047 [128.18]

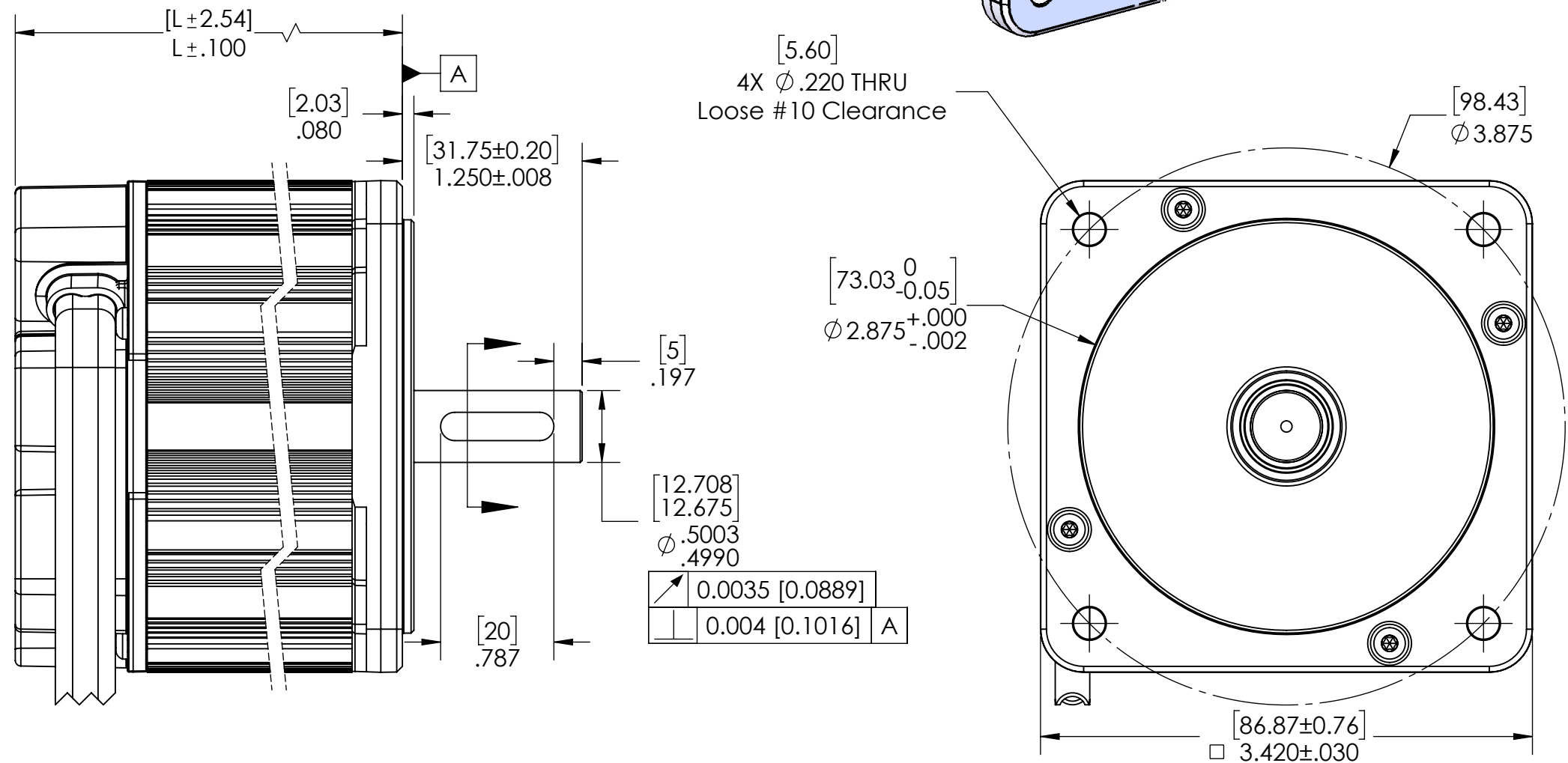
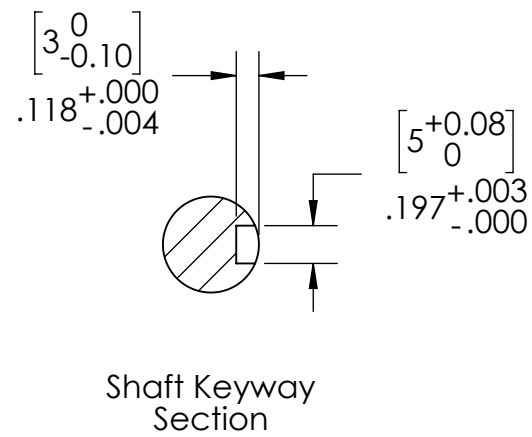
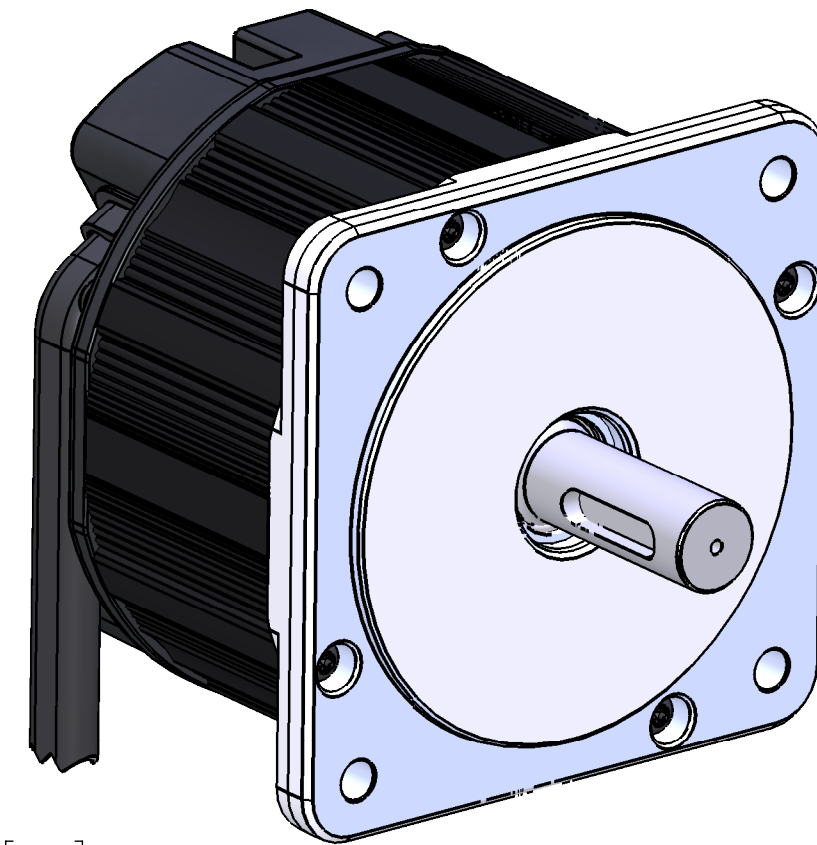

**Teknic, Incorporated**

Victor, NY 14564 USA

This document and related electronic files are the sole property of Teknic, Incorporated and contain proprietary information.

Third-Angle Projection

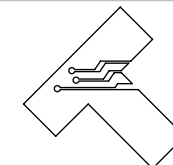

Additional documentation including product specifications, up-to-date compliance information, and manuals can be downloaded from Teknic's website.

Visit <https://www.teknic.com/> to access that documentation.

DWG. NO./REV

D1217/B

TITLE: 34xx Hudson Motor Family

1 of 1 Pages