

Teknic Hudson[®]

NEMA 23

- All dimensions are in inch [mm] unless otherwise noted.
- Sheet Scale 1:1
- Undimensioned features are per 3D file for model of interest for reference use.
- Unless otherwise specified, untoleranced dimensions are nonbasic and default to:
 - X.XX: ± .010" [0.25mm]
 - X.XXX: ± .005" [0.125mm]
 - Angles: ± 1°

Model Number	L
M-231 _ _ _ _	2.813 [71.44]
M-232 _ _ _ _	3.561 [90.44]
M-233 _ _ _ _	4.309 [109.44]
M-234 _ _ _ _	5.507 [128.44]

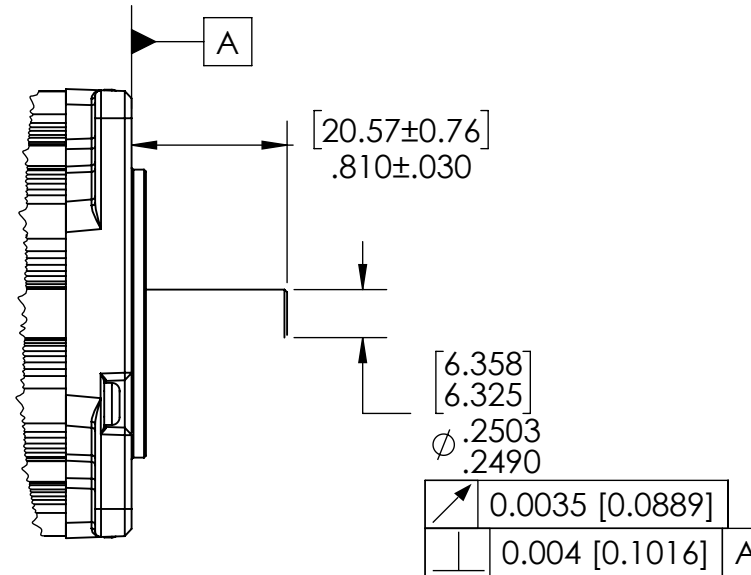

Optional 1/4" Full Round Shaft (No keyway)
Available for 231 and 232 Models

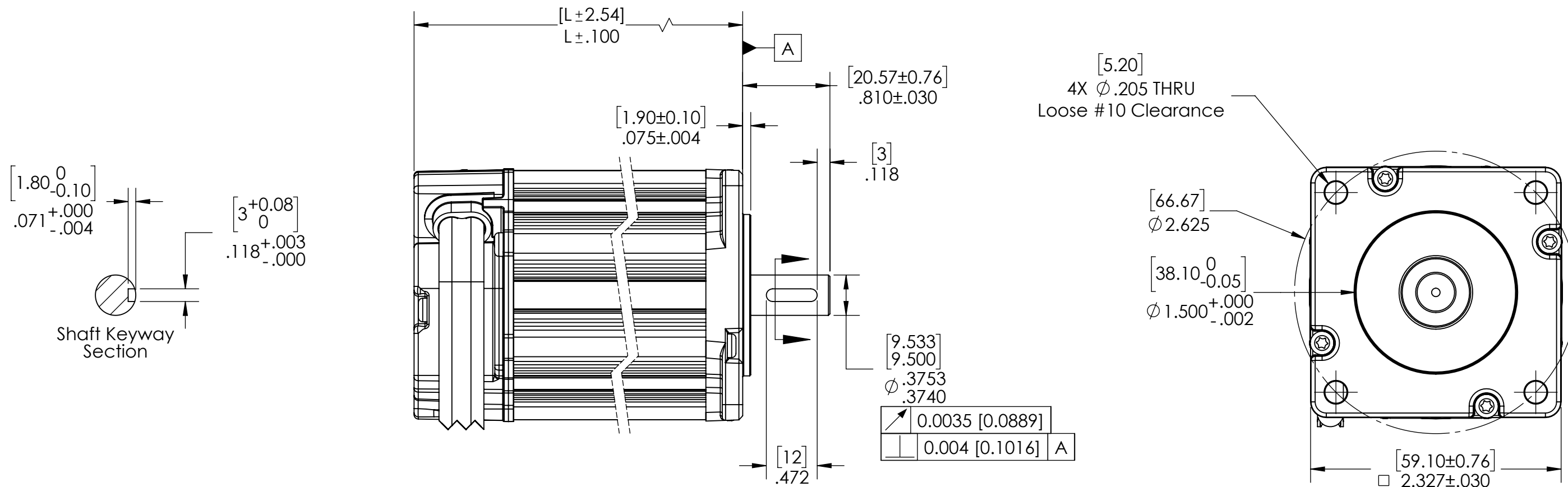
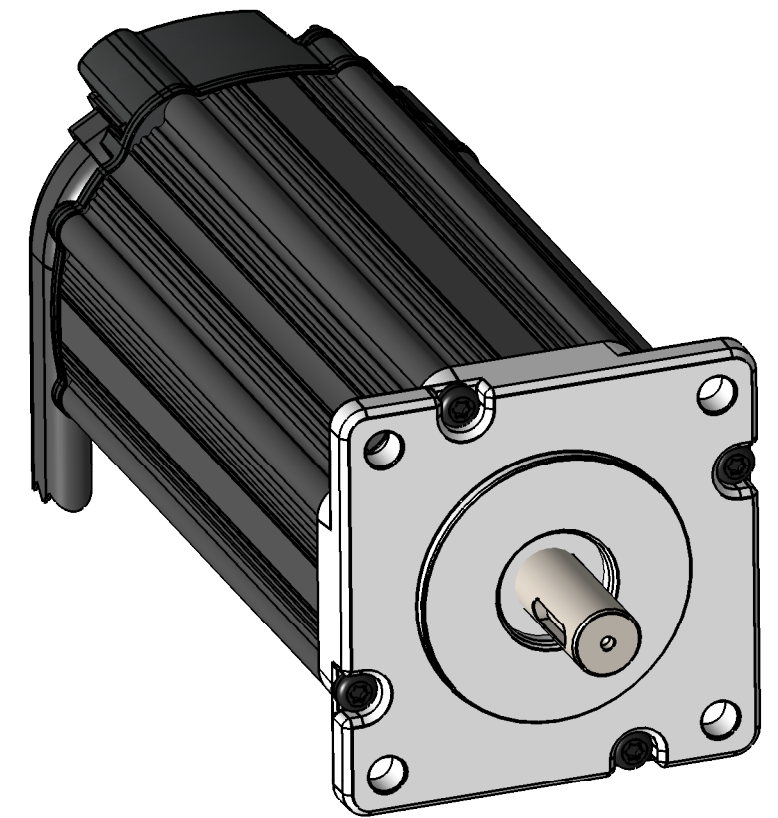

Teknic, Incorporated

Victor, NY 14564 USA

This document and related electronic files are the sole property of Teknic, Incorporated and contain proprietary information.

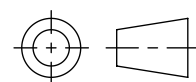

Third-Angle Projection

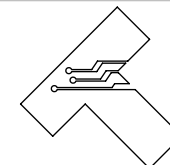

Additional documentation including product specifications, up-to-date compliance information, and manuals can be downloaded from Teknic's website.

Visit <https://www.teknic.com/> to access that documentation.

DWG. NO./REV

D1216/B

TITLE: 23xx Hudson Motor Family

1 of 1 Pages