

## MERIDIAN ISC HARDWARE REFERENCE MANUAL

MODELS ISC-M6xx/7xx

VERSION 2.4/SEPTEMBER 26, 2018

**THIS PAGE INTENTIONALLY LEFT BLANK**

# TABLE OF CONTENTS

TABLE OF CONTENTS.....	1
INTRODUCTION.....	2
Meridian ISC at a Glance .....	3
SAFETY.....	4
General Precautionary Statement .....	4
Symbols Used in this Manual .....	4
MECHANICAL INSTALLATION.....	5
Mounting Information.....	5
Mounting and Clearance Dimensions .....	6
Notes on EMI and Grounding .....	7
ELECTRICAL INSTALLATION .....	8
Overview: Electrical Isolation & Grounding .....	8
Grounding & Shielding Rules .....	8
Meridian I/O Interface (J1) .....	9
Wiring Examples: Meridian Output Devices .....	10
Wiring Examples: Meridian Input Devices.....	11
Power Supply Requirements (M6xx/M7xx).....	13
Connecting a Motor to the Meridian ISC .....	15
Overview .....	15
Connecting Teknic motors to Meridian-ISC 6xx/7xx .....	15
Connecting to Third Party Motors.....	15
Guidelines for Motor Cable Construction .....	17
Expansion Connector - P2 .....	18
Communications Connectors – J2, J3 .....	18
APPENDIX A: MERIDIAN ISC SPECIFICATIONS .....	19
APPENDIX B: GOLDEN RULES OF INSTALLATION ....	25
Power.....	25
Grounding and Shielding.....	25
Motor Cables .....	25
Cable Making Guidelines.....	26
General Recommendations .....	26
A Note on Hand Crimp Tools .....	27
APPENDIX C: CONNECTOR REFERENCE FOR MODELS M6XX/7XX.....	28

## INTRODUCTION

Thank you for choosing the Meridian Integrated Servo Controller (ISC). The Meridian ISC incorporates a high-fidelity servo drive, integral motion controller and local I/O. This combination results in a high-performance machine control solution that integrates the motion trajectory generator with the servo controller in an easily extensible system architecture.

Each Meridian ISC features a dedicated, high-speed digital signal processor (DSP) and onboard technology that supports the seamless integration of position, velocity, and torque loops. The unit's DSP monitors the real-time state of the position/velocity compensator, motor magnetic field, amplifier output voltages, limit switch inputs, RMS motor current, and more. This high speed data stream provides the foundation upon which the Meridian ISC produces state-of-the art motion.

The Meridian ISC is the result of our 20+ year history of hardware, software, and firmware development. That, combined with rapid advancements in DSP technology, allow Teknic to offer the systems designer benefits like:

- The ISC's high servo bandwidth ensures fast settling times, excellent tracking performance, ultra-smooth motion and tight velocity control for even the most demanding applications.
- Our wide power class and form factor options maximize selection flexibility by allowing the machine designer to select the most appropriate model based on specific power requirements, size constraints, integration needs with other devices and budgetary goals.
- Powerful and fully-integrated software prototyping tools enable the machine designer to quickly start electro-mechanical integration without the need for purpose-built software code resulting in faster time-to-market.

The Meridian ISC has the flexibility to control permanent magnet rotary and linear servomotors, voice coils, galvos, and most actuators on the market. Additionally, ISC units can be integrated together in an open control system architecture that leverages scalability and ease of development. The resulting solution provides excellent motion and I/O performance and outstanding overall value without the restrictions of proprietary systems.

# MERIDIAN ISC AT A GLANCE

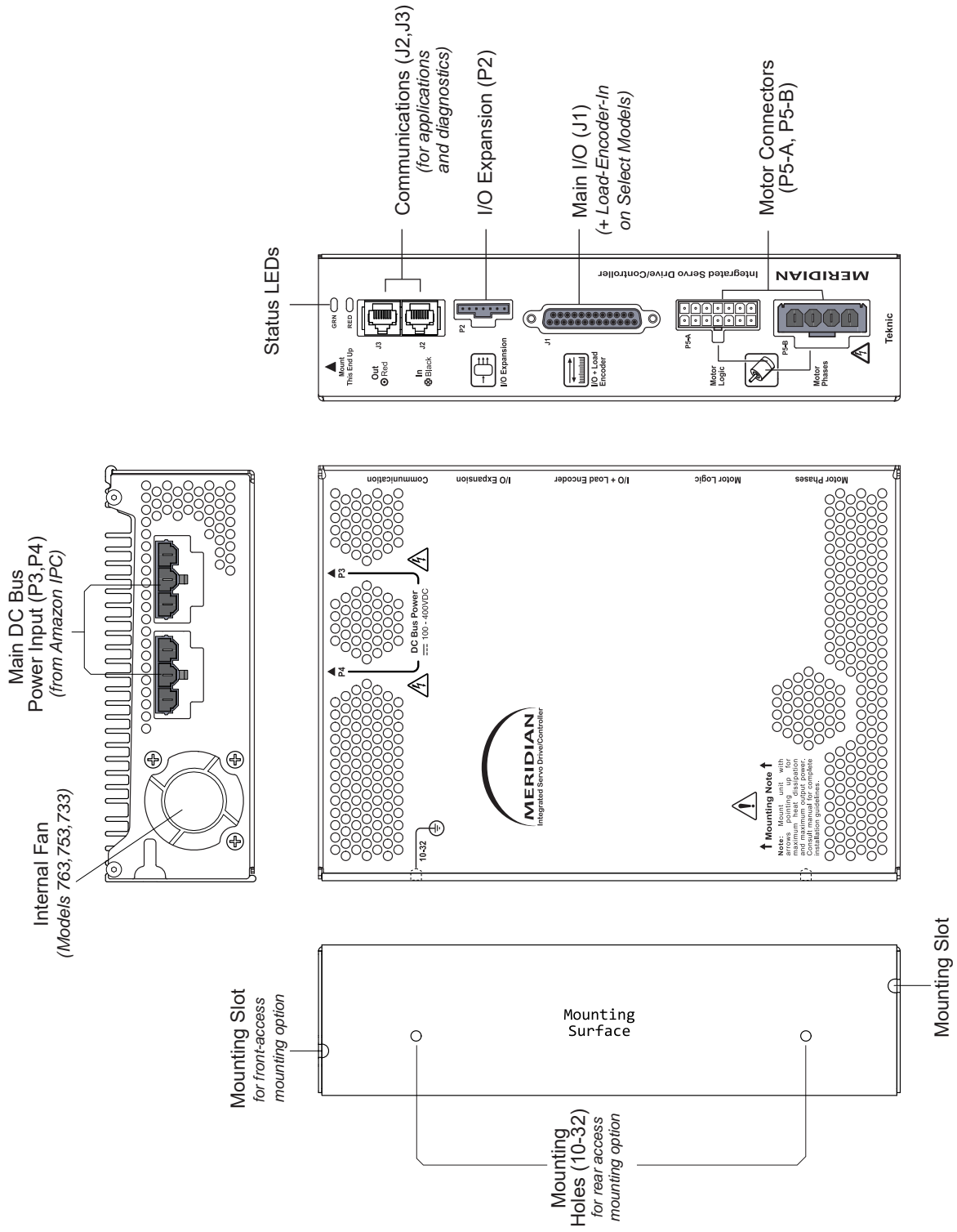

Meridian ISC (model ISC-M763-RCX shown)

# SAFETY

---

## GENERAL PRECAUTIONARY STATEMENT

Always follow appropriate safety precautions when installing and commissioning ISC units and motors. Equipment should be designed and utilized to prevent personnel from coming into contact with moving parts and electrical contacts that could potentially cause injury or death. Read all cautions, warnings and notes before attempting to operate or service motion control devices. Follow all applicable codes and standards when using this equipment. Failure to apply this equipment as described may impair or neutralize protections built into the product.

---

## SYMBOLS USED IN THIS MANUAL

The following symbols and conventions are used on the equipment and in this manual. Please read all equipment labels and manuals before attempting to use Meridian ISC units.

### Caution, risk of danger



Identifies information about practices or circumstances that can lead to equipment damage, personal injury, or loss of life.

### Shock hazard



Identifies presence of hazardous electrical voltages and currents.

### Protective earth terminal



Indicates points that must be connected to a reliable earth system for safety compliance. Protective earth connections should never be omitted.



### Earth ground terminal



### Frame or chassis terminal (shield)



### Direct current

### Note



Identifies information that is critical for successful application and understanding of the product.

### Tip



Identifies additional information that may be helpful in supporting certain applications.

# MECHANICAL INSTALLATION

This section discusses mounting requirements for the Meridian ISC models M6xx/7xx.

## MOUNTING INFORMATION

For the most effective heat dissipation, maximum continuous output power, and highest reliability, follow these mounting guidelines:

- Mount all Meridian units as shown below. Drives should be screwed to a thermally conductive material such as steel or aluminum machine frame to provide maximum heat sinking.
- Follow minimum clearance and spacing guidelines to ensure proper air flow through, around, and between Meridian units. See mounting diagrams for important clearance and spacing requirements.
- The Meridian ISC is rated for operation in ambient air temperatures of 0-40C (32-104F).

**Note:** For cabinet-mount installations:

- Mount Meridian ISC near the bottom of cabinet where air is cooler.
- Use forced air cooling to improve performance and add operating margin. At minimum, mount units in a vented enclosure that does not exceed maximum ambient air temperature, even during the most demanding machine operations.
- Avoid mounting Meridian ISCs above heat sources such as power supplies, transformers, or spindle drives.

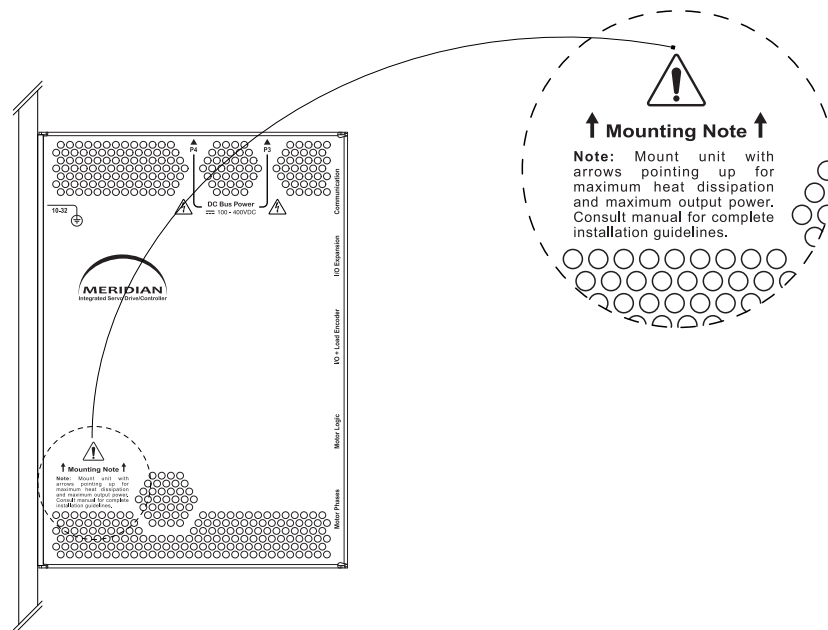

**Meridian drive mounting orientation**

# MOUNTING AND CLEARANCE DIMENSIONS

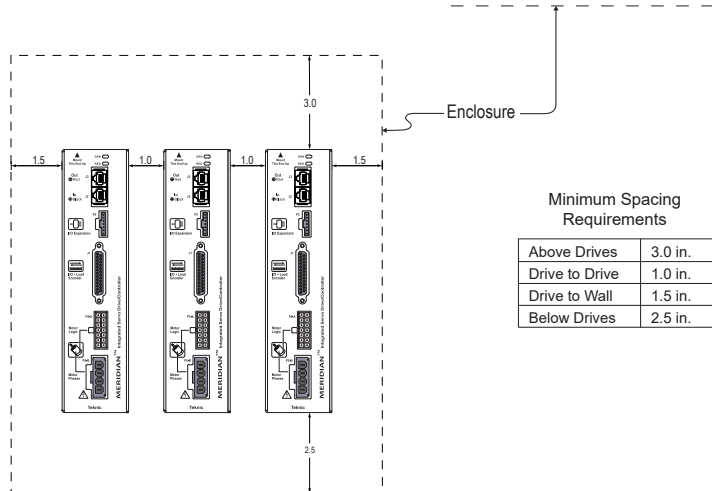
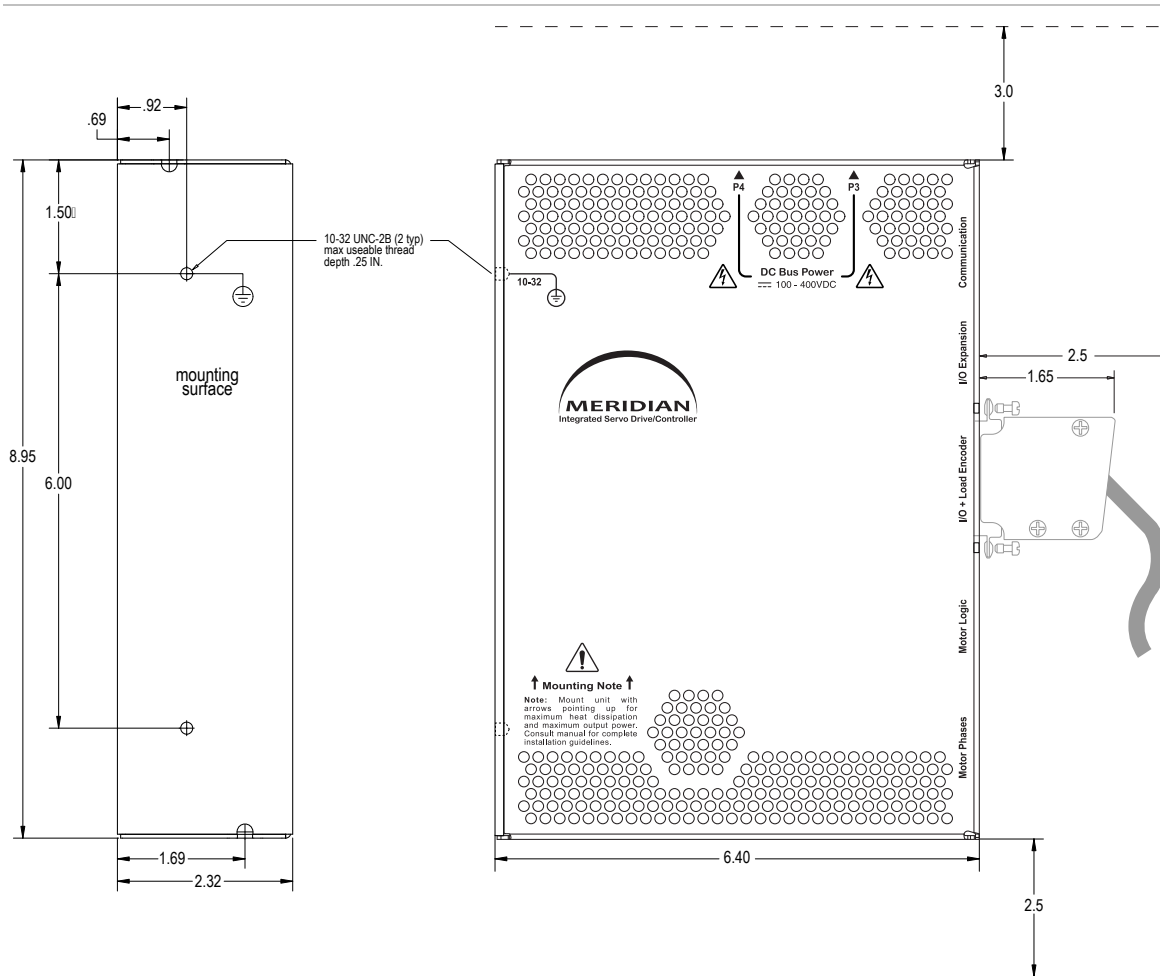

**Mounting and clearance dimensions (M6xx/M7xx models)**



## NOTES ON EMI AND GROUNDING

Electromagnetic Interference (EMI) can affect the quality and integrity of digital signals used in servo systems. One key to EMI suppression is to provide a low impedance RF return path between the motor case and the servo drive.

**When using a third-party motor with your Meridian ISC unit,** verify that the following conditions exist:

- The motor phase shield is bonded to the motor case.
- The motor phase shield is terminated at the motor cable connector. See Appendix C for Meridian connector and pin designations.
- The motor extension cable (if used) carries the phase shield (uninterrupted) all the way back to the drive.
- The motor phase shield does not contact or intermingle with the encoder/commutation signal shield at any point.
- Additionally, to lessen the potential for ground loops:
  - The communications power supply (24-42VDC) should be connected to the system only through the CON-MOD component as this component provides isolation and filtering.
  - No signal ground or I/O ground should be connected to chassis ground at any point.



**Note:** The Meridian's protective earth connection is made through the two mounting holes on the case extrusion. Connect these mounting holes to chassis ground ensuring direct metal to metal (unpainted) contact.

# ELECTRICAL INSTALLATION

Many time-saving and cost-saving details are presented in the schematic fragments and text that follow. Please read this entire section, as well as the “Golden Rules of Installation”, before integrating Meridian ISC units into your machine.

---

## OVERVIEW: ELECTRICAL ISOLATION & GROUNDING

In order to prevent ground loops in Meridian ISC systems, the control ground, power circuits, and chassis are electrically isolated from each other.

All logic-level signals are electrically isolated from the Meridian ISC's DC power input and motor output circuits, as well as from the Meridian ISC's chassis (case ground). This design feature ensures that control signals will not be compromised by induced currents from the motor, power supply, or PWM return path. You can also daisy-chain the power wiring to multiple Meridian ISCs. This simplifies wiring requirements while simultaneously reducing cost and increasing system reliability.



**Note:** Always maintain separation between isolated control ground and power ground. See Appendix B, “Golden Rules of Installation”, for more details.

## GROUNDING & SHIELDING RULES

In order to meet EMC emissions specification EN-61000-6-4, and EMC immunity specification EN-61000-6-2, as well as EMC electrical safety specification EN-61010 (for CE/UL compliance) the following rules must be followed:

1. **The ISC's Protective Earth (PE) Ground must be connected to the machine's safety ground.**
2. **The motor phase cable must be shielded.** The shield must be connected to the motor case (on the motor end) and to the Chassis pin on the ISC motor connector (see Appendix C). The shield lead length at both ends of the cable should be as short as possible with a 2.0" maximum length.
3. **The encoder and commutation sensor (Hall) cable must be separately shielded** from the motor phase cable (even though the motor and encoder shields connect to the ISC chassis) in order to prevent motor PWM noise from traveling through the encoder shield. The motor and encoder shields **must not** touch at any point. The shield for the encoder cable must be left unconnected at the motor end (don't connect it to the motor's case).



**Note:** In scenarios where the motor is isolated from proper ground return paths (as when bench testing) temporary measures should be taken to comply with safety grounding requirements. Failure to do so can result in mechanical and/or electrical hazards.

## MERIDIAN I/O INTERFACE (J1)

The Meridian ISC is compatible with most typical I/O devices. This section contains a few example hook up diagrams for common I/O devices including LEDs, incandescent lamps, SSRs, coils, limit switches, mechanical switches, and open collector devices/sensors.

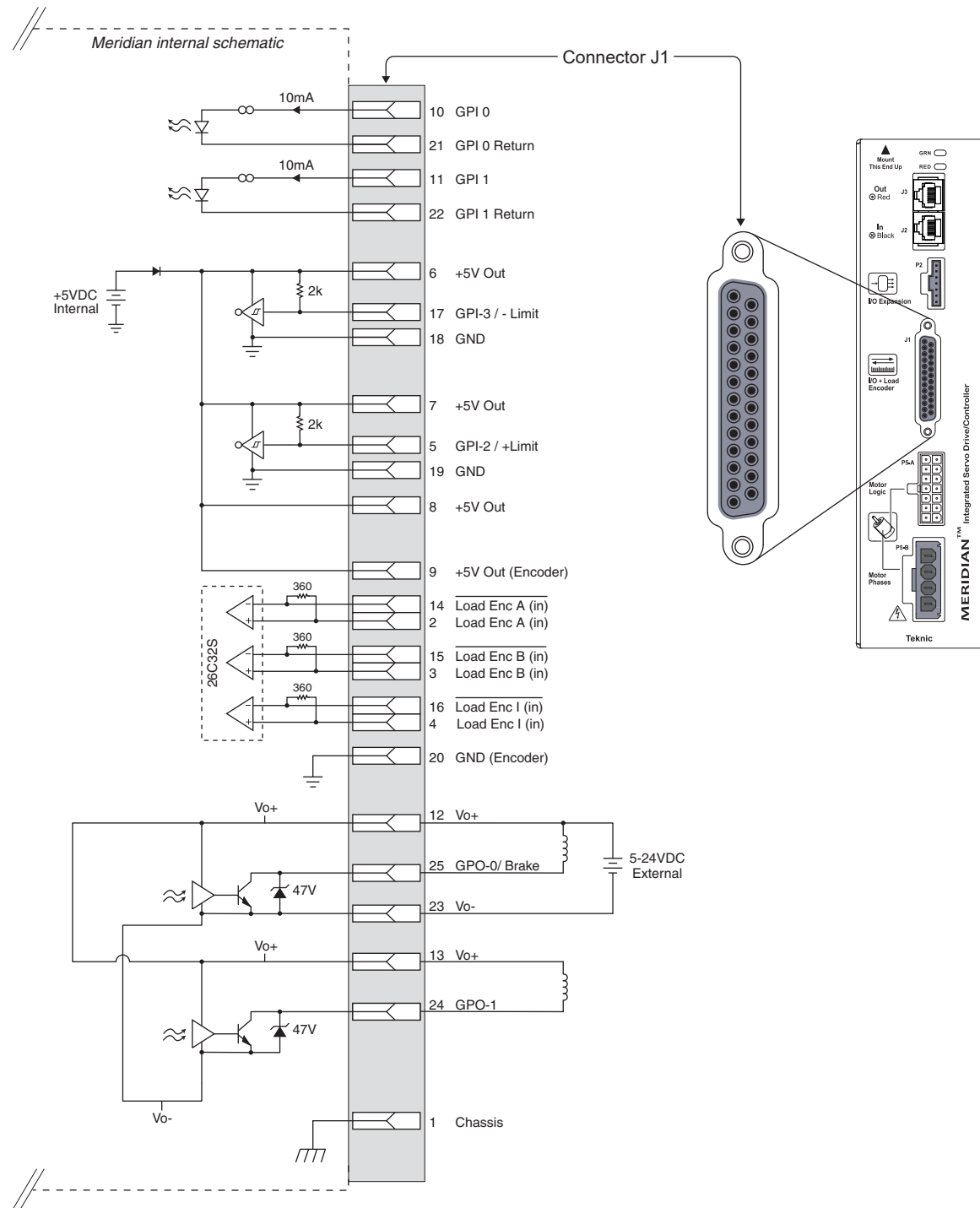

**Meridian controller connector (J1) and schematic fragments**

**WIRING EXAMPLES: MERIDIAN OUTPUT DEVICES**

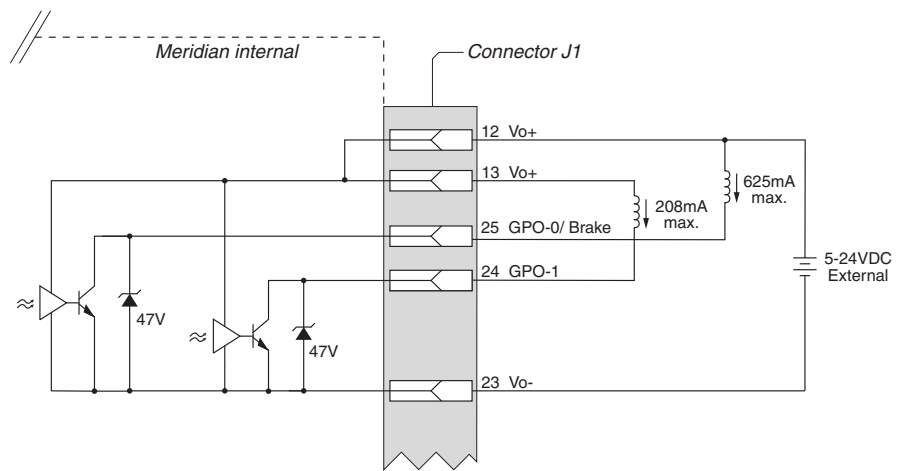

**Coils/Brakes**

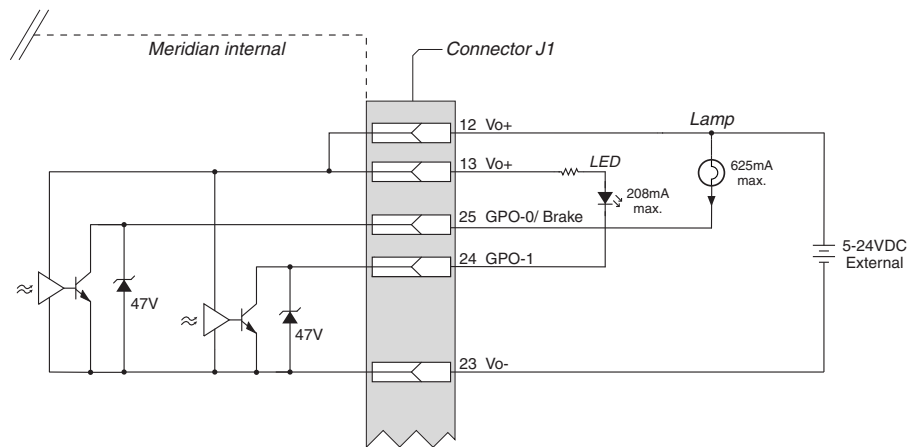

**LED and incandescent indicator lamps**

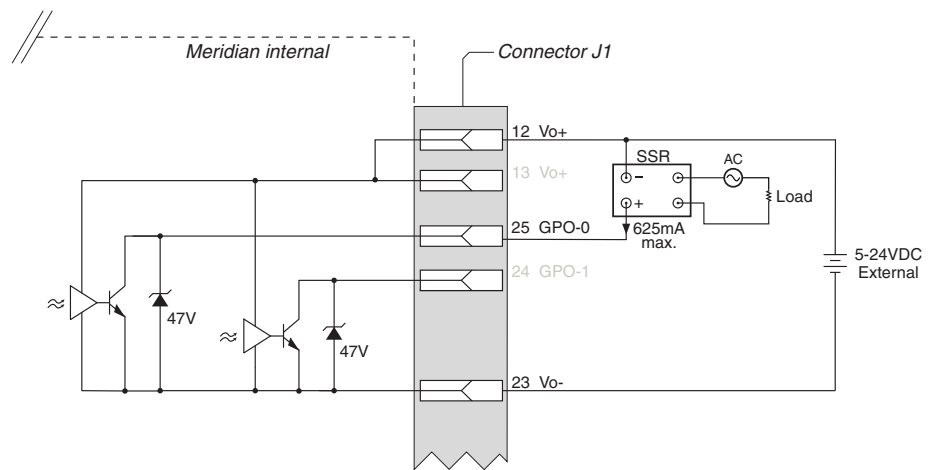

**Solid state relay (SSR) with external AC load**

**WIRING EXAMPLES: MERIDIAN INPUT DEVICES**

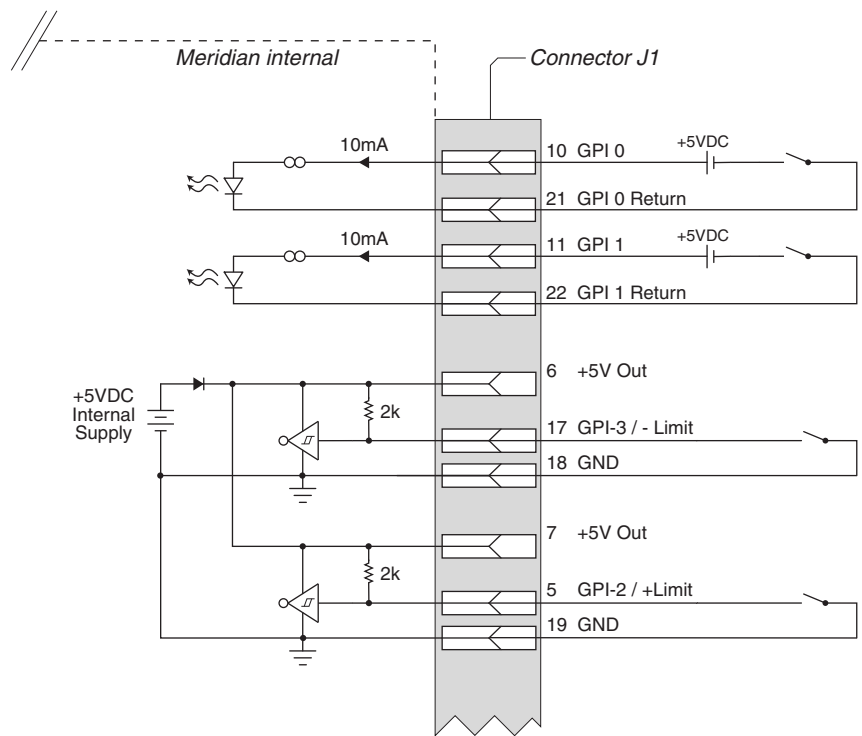

**Simple mechanical switches**

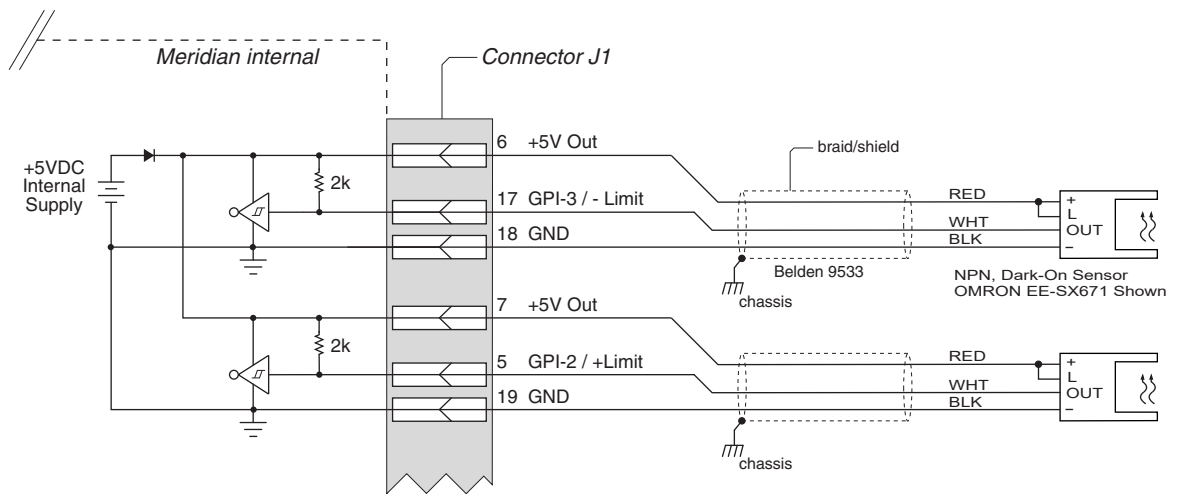

**Limit switches**

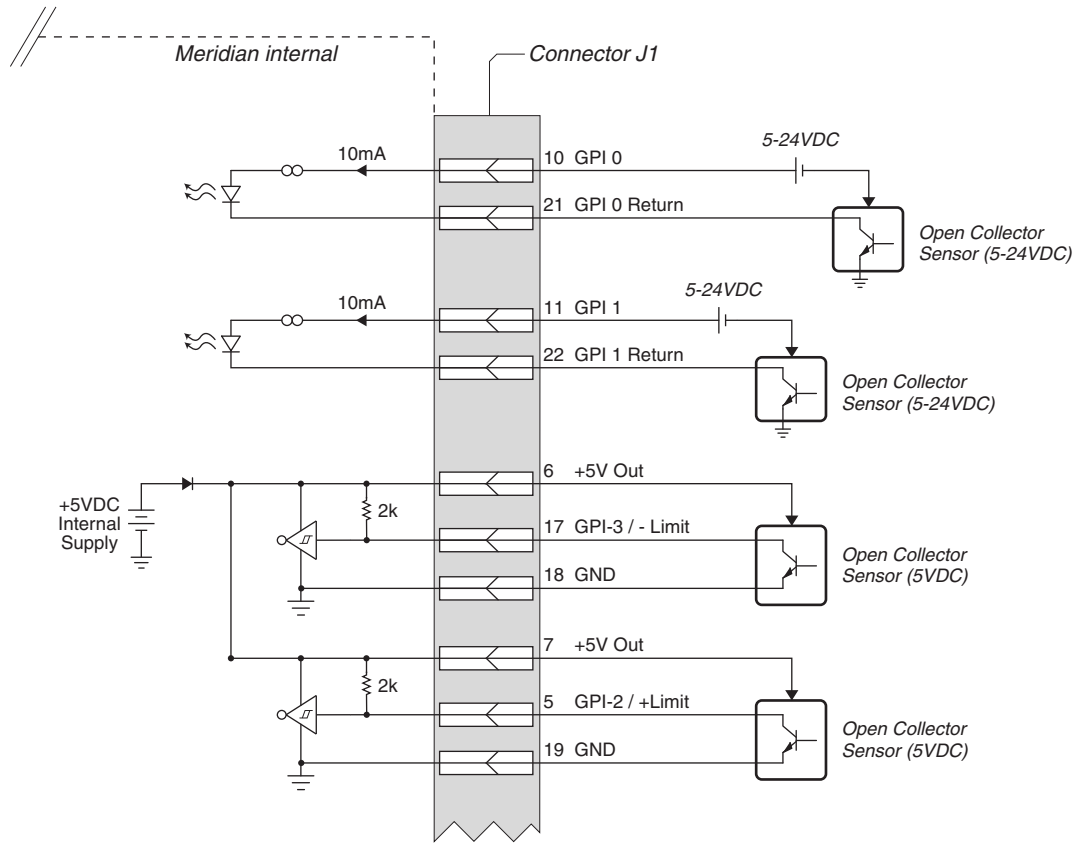

**5 and 24VDC sensors**

## POWER SUPPLY REQUIREMENTS (M6XX/M7XX)

Teknic offers a power supply specifically designed for the higher powered Meridian 6xx/7xx models; the DSP-based **Amazon Intelligent Power Center<sup>1</sup> (IPC)**.

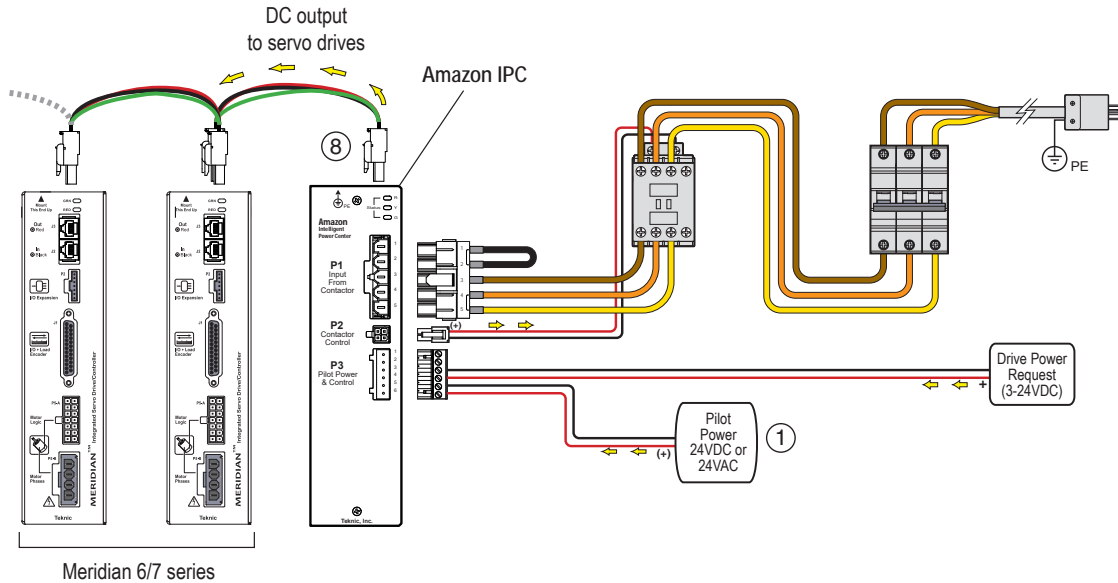

### Amazon Intelligent Power Center (IPC) powering two Meridian ISCs

The Amazon IPC does more than supply power to Meridian 6 and 7 series drives. Teknic engineers have designed many standard and optional features into the Amazon IPC to help reduce up front design and engineering effort, improve system reliability, and reduce overall machine cost for our OEM machine manufacturers.

Standard Amazon IPC features (all models) include:

- Multiple AC input voltages: Single phase 100-250VAC, three phase 100-250VAC, and 5-wire 380-415VAC
- Input contactor control
- Regenerated energy management
- Over-voltage/over-current detection and protection
- Reverse load polarity detection and protection

Optional features (advanced models) include:

- Input contactor safety monitoring
- EMI filtering
- Voltage droop detection
- Status outputs (3 total)
- E-stop interlock switch input

<sup>1</sup> See Amazon IPC Installation and Use Guide for complete safety and application information.

- Safety fault annunciation (siren)
- RS-232 configurable
- System event logs

Whether you need a basic power supply or a safety compliant power management system, the Amazon IPC can replace the list of components previously needed to manage machine power at a lower total cost. Refer to the Amazon IPC user manual or your Teknic Applications Engineer for more information.



## CONNECTING A MOTOR TO THE MERIDIAN ISC

### OVERVIEW

Meridian ISCs can elegantly control not only Teknic servo motors, but also most third-party motors, including brush and brushless servo motors, linear motors, galvos, voice coils, and more. The following section describes how to connect the Meridian ISC to both Teknic, and third-party motors.

### CONNECTING TEKNIC MOTORS TO MERIDIAN-ISC 6XX/7XX

M6xx/7xx drives include a two-part motor connector as shown below. Connector P5-A carries the low voltage motor logic signals (encoder, commutation, etc.); P5-B carries the motor phases.

Note: Minimum wire gauge for motor phases may vary depending on the Meridian model selected and the specific application power requirements. See your Applications Engineer if you need assistance selecting an appropriate wire gauge.

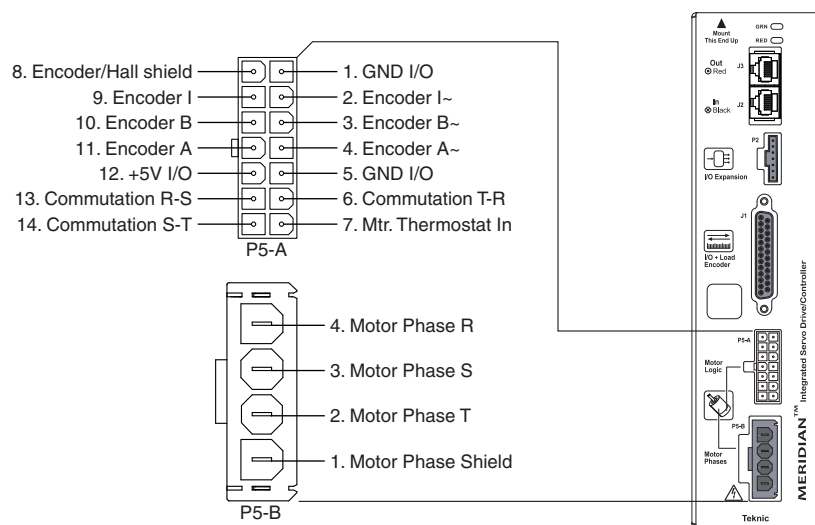

**Motor Connectors P5-A and P5-B (M6xx/M7xx models)**

### CONNECTING TO THIRD PARTY MOTORS

The section below provides schematics, guidelines, and other details to follow when connecting a third party (non-Teknic) motor to a Meridian ISC.

Mating connectors are specified in Appendix C (connector reference). Belden cable products are economical and have excellent electrical properties. They are a good choice for non-flex applications, but they are not appropriate for use in high-flex applications.

Olflex and others manufacture make high-flex cable products designed (and lab tested) to withstand millions of flex cycles. Your Teknic

Application Engineer can recommend an appropriate cable stock for your project requirements.

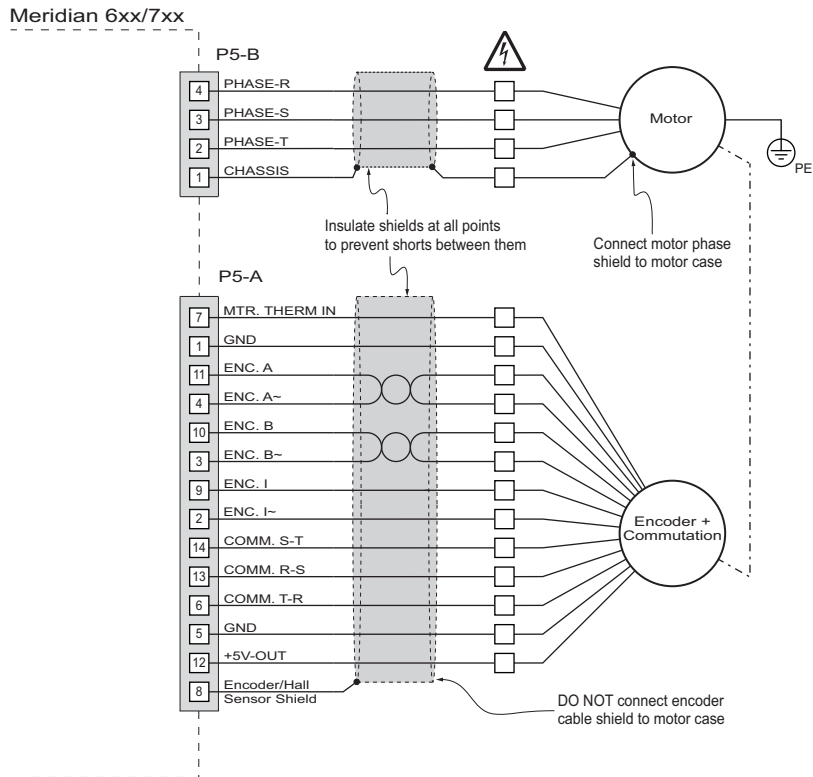

**Meridian motor cable (balanced encoder)**

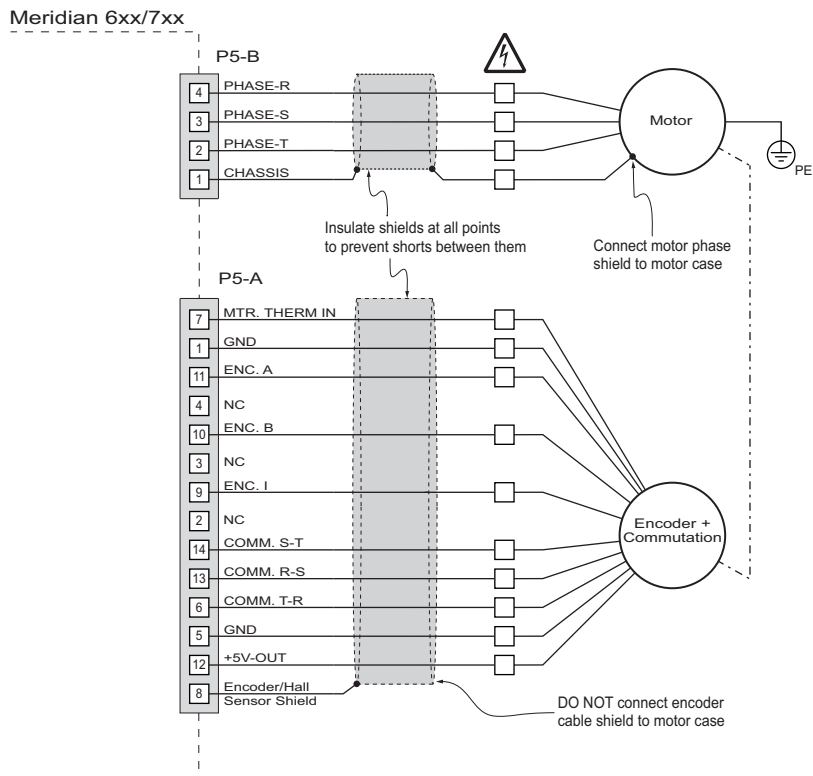

**Meridian motor cable (single-ended encoder)**



**Note:** Teknic motor pigtails are not designed for high-flex use. Always strain relieve the motor pigtail to prevent continuous flexing and eventual cable damage.



**Tip:** There is no standard naming convention for motor phases, commutation sensor signals, or encoder signals. What Teknic labels as “Motor Phase R”, another servo company may label “Motor Phase X”, or “Motor Phase B”. This holds true of encoder signals and commutation sensor signals as well. Contact Teknic for assistance with third-party motor connections for the Meridian drive.

## GUIDELINES FOR MOTOR CABLE CONSTRUCTION

Motor cables for Meridian products should be constructed according to the following:

1. Motor phase leads should be kept as short as possible after they exit the cable shield, preferably under 2”.
2. The motor phase cable shield termination should be kept short at both ends, preferably under 2”.
3. Use 16AWG or larger shielded cable for the motor phases.
4. Use low capacitance, shielded twisted pair cable for the encoder and commutation sensor signals, if possible.
5. Commutation sensor signals (Hall sensors) should be run in the encoder cable and NOT in the motor phase cable.
6. **The shield on the motor phase cable must not come in contact with the shield of the encoder cable at any point.** Cover exposed shield and drain wires with heat shrink tubing at termination points to prevent this. Failure to isolate these shields can result in loss of logic signal integrity and spurious failures and shutdowns.
7. Connect the motor phase cable shield to the motor case.
8. DO NOT connect the encoder cable shield to the motor case.

**Warning!** When connecting and disconnecting motors from Meridian ISCs:



1. Always disable the Meridian ISC before connecting or disconnecting a motor.
2. Verify that the proper motor configuration file is loaded in the Meridian unit before enabling it with a motor connected. This is particularly important if the configuration file currently loaded in the ISC is unknown, or if you have connected a different type of motor to the ISC.
3. Always reset the ISC after connecting or reconnecting a motor to it.

---

## EXPANSION CONNECTOR - P2

---

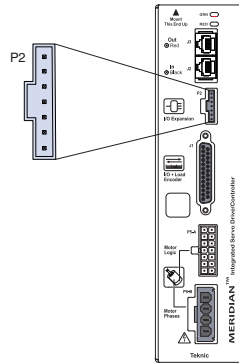

*Meridian Expansion Connector (P2)*

---

## COMMUNICATIONS CONNECTORS – J2, J3

---

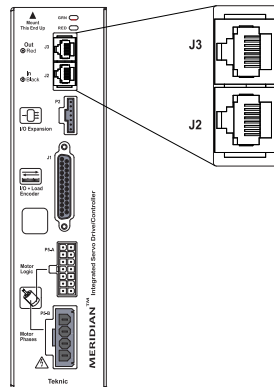

*Meridian Diagnostic and Application Communications Connectors*

# APPENDIX A: MERIDIAN ISC SPECIFICATIONS

ISC-M763-RCX Specifications		
GENERAL	Dimensions, in (mm):	8.95 (227) x 6.40 (163) x 2.32 (59)
	Weight, oz (g):	53.5 (1515)
ENVIRONMENTAL	Temperature:	0-40°C
	Humidity:	0-90%, non-condensing
COMPLIANCE	Electrical safety:	EN 61010, UL508C
	EMI:	EN 61326
	Machine safety:	EN 954-1, with proper power control
INTERNAL FAN		Yes
OUTPUT POWER	Peak Current:	50A
	Continuous Current:	20A RMS
	PWM ripple frequency:	28kHz, center balance vector type
	Conversion Efficiency:	>99%
COMPENSATOR	TSPD:	35 $\mu$ S
	Position/Velocity control:	Enhanced PIV with proprietary velocity, acceleration and jerk estimators, Inertia Matching Technology (IMT), Regressive AutoSpline (RAS) and Anti-Hunt. Provides velocity, acceleration, jerk, and friction feed-forward gains
	Torque control:	Synchronous vector with DQ decoupling, SmartSaturation, and auto calibration
ENCODER	Interface:	Primary: Single-ended or differential, user selectable
	Features:	Bad sequence detection, digital filtering adjustable from 100kHz to 40MHz Secondary (load) encoder supported
MOTOR COMPATIBILITY	Requirements:	Rotary brush or 3-phase brushless rotary/linear motor
HALL SENSOR INPUTS	Specifications:	5k $\Omega$ pull-up to +5V
	Features:	Digitally filtered; used for setting torque vector upon initialization only; drive can also operate in Hall-less mode
DEDICATED INTERFACE	Interface:	5k $\Omega$ pull-up to +3.3VDC; digitally filtered
OUTPUTS	GPO-0, GPO-1	Isolated, short-circuit protected, open collector outputs. 47V (active) clamping for directly driving inductive loads. Requires external 4-28VDC power supply
		GPO-0 625mA GPO-1 208mA
INPUTS	GPI-0, GPI-1	High-speed, optically isolated, Response time < 200nS, Operating voltage 4-28VDC requires 10mA, Can be used as capture inputs
	GPI-2, GPI-3	Can be user-configured as limit switch inputs, TTL with 2k pull-up, digitally filtered
PROTECTION & SAFETY FUNCTIONS	Drive protection:	Short circuit (phase-to-phase, phase-to-ground), over temp, over voltage, over current, protected for open windings, fused.
	Motor protection:	True RMS torque limiting, automatic speed limit, motor jam detection, over temp
	Mechanical safeguards:	Hardstop detection, limit switch servoing, adjustable tracking error limits and shutdown thresholds, adjustable torque and speed limits
	Electrical Isolation:	6.0mm (0.236")
OTHER	+5VDC out of motor connector (encoder/hall power)	300mA max.
	Dual encoder support	Yes
INPUT SUPPLY	Input voltage/current: Main DC (bus) power supply	130-360VDC (derived from IPC @ 90-250VAC, single or 3-phase)
	Input current (max) Input current (typical)	15A RMS 5A RMS, application dependent
COUNTRY OF ORIGIN	Manufactured in:	USA

ISC-M753-RCX Specifications		
GENERAL	Dimensions, in (mm):	8.95 (227) x 6.40 (163) x 2.32 (59)
	Weight, oz (g):	53.5 (1515)
ENVIRONMENTAL	Temperature:	0-40°C
	Humidity:	0-90%, non-condensing
COMPLIANCE	Electrical safety:	EN 61010, UL508C
	EMI:	EN 61326
	Machine safety:	EN 954-1, with proper power control
INTERNAL FAN		Yes
OUTPUT POWER	Peak Current:	30A
	Continuous Current:	15A RMS
	PWM ripple frequency:	28kHz, center balance vector type
	Conversion Efficiency:	>99%
COMPENSATOR	TSPD:	35 $\mu$ S
	Position/Velocity control:	Enhanced PIV with proprietary velocity, acceleration and jerk estimators, Inertia Matching Technology (IMT), Regressive AutoSpline (RAS) and Anti-Hunt. Provides velocity, acceleration, jerk, and friction feed-forward gains
	Torque control:	Synchronous vector with DQ decoupling, SmartSaturation, and auto calibration
ENCODER	Interface:	Primary: Single-ended or differential, user selectable
	Features:	Bad sequence detection, digital filtering adjustable from 100kHz to 40MHz Secondary (load) encoder supported
MOTOR COMPATIBILITY	Requirements:	Rotary brush or 3-phase brushless rotary/linear motor
HALL SENSOR INPUTS	Specifications:	5k $\Omega$ pull-up to +5V
	Features:	Digitally filtered; used for setting torque vector upon initialization only; drive can also operate in Hall-less mode
DEDICATED INTERFACE	Interface:	5k $\Omega$ pull-up to +3.3VDC; digitally filtered
OUTPUTS	GPO-0, GPO-1	Isolated, short-circuit protected, open collector outputs. 47V (active) clamping for directly driving inductive loads. Requires external 4-28VDC power supply GPO-0 625mA GPO-1 208mA
INPUTS	GPI-0, GPI-1	High-speed, optically isolated, Response time < 200nS, Operating voltage 4-28VDC requires 10mA, Can be used as capture inputs
	GPI-2, GPI-3	Can be user-configured as limit switch inputs, TTL with 2k pull-up, digitally filtered
PROTECTION & SAFETY FUNCTIONS	Drive protection:	Short circuit (phase-to-phase, phase-to-ground), over temp, over voltage, over current, protected for open windings, fused.
	Motor protection:	True RMS torque limiting, automatic speed limit, motor jam detection, over temp
	Mechanical safeguards:	Hardstop detection, limit switch servoing, adjustable tracking error limits and shutdown thresholds, adjustable torque and speed limits
	Electrical Isolation:	6.0mm (0.236")
OTHER	+5VDC out of motor connector (encoder/hall power)	300mA max.
	Dual encoder support	Yes
INPUT SUPPLY	Input voltage/current: Main DC (bus) power supply	130-360VDC (derived from IPC @ 90-250VAC, single or 3-phase)
	Input current (max) Input current (typical)	15A RMS 5A RMS, application dependent
COUNTRY OF ORIGIN	Manufactured in:	USA

ISC-M733-RCX Specifications		
GENERAL	Dimensions, in (mm):	8.95 (227) x 6.40 (163) x 2.32 (59)
	Weight, oz (g):	53.5 (1515)
ENVIRONMENTAL	Temperature:	0-40°C
	Humidity:	0-90%, non-condensing
COMPLIANCE	Electrical safety:	EN 61010, UL508C
	EMI:	EN 61326
	Machine safety:	EN 954-1, with proper power control
INTERNAL FAN		Yes
OUTPUT POWER	Peak Current:	23A
	Continuous Current:	12A RMS
	PWM ripple frequency:	28kHz, center balance vector type
	Conversion Efficiency:	>99%
COMPENSATOR	TSPD:	35 $\mu$ S
	Position/Velocity control:	Enhanced PIV with proprietary velocity, acceleration and jerk estimators, Inertia Matching Technology (IMT), Regressive AutoSpline (RAS) and Anti-Hunt. Provides velocity, acceleration, jerk, and friction feed-forward gains
	Torque control:	Synchronous vector with DQ decoupling, SmartSaturation, and auto calibration
ENCODER	Interface:	Primary: Single-ended or differential, user selectable
	Features:	Bad sequence detection, digital filtering adjustable from 100kHz to 40MHz Secondary (load) encoder supported
MOTOR COMPATIBILITY	Requirements:	Rotary brush or 3-phase brushless rotary/linear motor
HALL SENSOR INPUTS	Specifications:	5k $\Omega$ pull-up to +5V
	Features:	Digitally filtered; used for setting torque vector upon initialization only; drive can also operate in Hall-less mode
DEDICATED INTERFACE	Interface:	5k $\Omega$ pull-up to +3.3VDC; digitally filtered
OUTPUTS	GPO-0, GPO-1	Isolated, short-circuit protected, open collector outputs. 47V (active) clamping for directly driving inductive loads. Requires external 4-28VDC power supply GPO-0 625mA GPO-1 208mA
INPUTS	GPI-0, GPI-1	High-speed, optically isolated, Response time < 200nS, Operating voltage 4-28VDC requires 10mA, Can be used as capture inputs
	GPI-2, GPI-3	Can be user-configured as limit switch inputs, TTL with 2k pull-up, digitally filtered
PROTECTION & SAFETY FUNCTIONS	Drive protection:	Short circuit (phase-to-phase, phase-to-ground), over temp, over voltage, over current, protected for open windings, fused.
	Motor protection:	True RMS torque limiting, automatic speed limit, motor jam detection, over temp
	Mechanical safeguards:	Hardstop detection, limit switch servoing, adjustable tracking error limits and shutdown thresholds, adjustable torque and speed limits
	Electrical Isolation:	6.0mm (0.236")
OTHER	+5VDC out of motor connector (encoder/hall power)	300mA max.
	Dual encoder support	Yes
INPUT SUPPLY	Input voltage/current: Main DC (bus) power supply	130-360VDC (derived from IPC @ 90-250VAC, single or 3-phase)
	Input current (max) Input current (typical)	15A RMS 5A RMS, application dependent
COUNTRY OF ORIGIN	Manufactured in:	USA

ISC-M723-RCX Specifications		
GENERAL	Dimensions, in (mm):	8.95 (227) x 6.40 (163) x 2.32 (59)
	Weight, oz (g):	53.5 (1515)
ENVIRONMENTAL	Temperature:	0-40°C
	Humidity:	0-90%, non-condensing
COMPLIANCE	Electrical safety:	EN 61010, UL508C
	EMI:	EN 61326
	Machine safety:	EN 954-1, with proper power control
INTERNAL FAN		Yes
OUTPUT POWER	Peak Current:	16A
	Continuous Current:	7A RMS
	PWM ripple frequency:	28kHz, center balance vector type
	Conversion Efficiency:	>99%
COMPENSATOR	TSPD:	35 $\mu$ S
	Position/Velocity control:	Enhanced PIV with proprietary velocity, acceleration and jerk estimators, Inertia Matching Technology (IMT), Regressive AutoSpline (RAS) and Anti-Hunt. Provides velocity, acceleration, jerk, and friction feed-forward gains
	Torque control:	Synchronous vector with DQ decoupling, SmartSaturation, and auto calibration
ENCODER	Interface:	Primary: Single-ended or differential, user selectable
	Features:	Bad sequence detection, digital filtering adjustable from 100kHz to 40MHz Secondary (load) encoder supported
MOTOR COMPATIBILITY	Requirements:	Rotary brush or 3-phase brushless rotary/linear motor
HALL SENSOR INPUTS	Specifications:	5k $\Omega$ pull-up to +5V
	Features:	Digitally filtered; used for setting torque vector upon initialization only; drive can also operate in Hall-less mode
DEDICATED INTERFACE	Interface:	5k $\Omega$ pull-up to +3.3VDC; digitally filtered
OUTPUTS	GPO-0, GPO-1	Isolated, short-circuit protected, open collector outputs. 47V (active) clamping for directly driving inductive loads. Requires external 4-28VDC power supply
		GPO-0 625mA GPO-1 208mA
INPUTS	GPI-0, GPI-1	High-speed, optically isolated, Response time < 200nS, Operating voltage 4-28VDC requires 10mA, Can be used as capture inputs
	GPI-2, GPI-3	Can be user-configured as limit switch inputs, TTL with 2k pull-up, digitally filtered
PROTECTION & SAFETY FUNCTIONS	Drive protection:	Short circuit (phase-to-phase, phase-to-ground), over temp, over voltage, over current, protected for open windings, fused.
	Motor protection:	True RMS torque limiting, automatic speed limit, motor jam detection, over temp
	Mechanical safeguards:	Hardstop detection, limit switch servoing, adjustable tracking error limits and shutdown thresholds, adjustable torque and speed limits
	Electrical Isolation:	6.0mm (0.236")
OTHER	+5VDC out of motor connector (encoder/hall power)	300mA max.
	Dual encoder support	Yes
INPUT SUPPLY	Input voltage/current: Main DC (bus) power supply	130-360VDC (derived from IPC @ 90-250VAC, single or 3-phase)
	Input current (max) Input current (typical)	15A RMS 5A RMS, application dependent
COUNTRY OF ORIGIN	Manufactured in:	USA



<b>ISC-M623-KCX Specifications</b>		
GENERAL	Dimensions, in (mm):	8.95 (227) x 6.40 (163) x 2.32 (59)
	Weight, oz (g):	53.5 (1515)
ENVIRONMENTAL	Temperature:	0-40°C
	Humidity:	0-90%, non-condensing
COMPLIANCE	Electrical safety:	EN 61010, UL508C
	EMI:	EN 61326
	Machine safety:	EN 954-1, with proper power control
INTERNAL FAN		Not required
OUTPUT POWER	Peak Current:	13A
	Continuous Current:	5A RMS
	PWM ripple frequency:	28kHz, center balance vector type
	Conversion Efficiency:	>99%
COMPENSATOR	TSPD:	35 $\mu$ S
	Position/Velocity control:	Enhanced PIV with proprietary velocity, acceleration and jerk estimators, Inertia Matching Technology (IMT), Regressive AutoSpline (RAS) and Anti-Hunt. Provides velocity, acceleration, jerk, and friction feed-forward gains
	Torque control:	Synchronous vector with DQ decoupling, SmartSaturation, and auto calibration
ENCODER	Interface:	Primary: Single-ended or differential, user selectable
	Features:	Bad sequence detection, digital filtering adjustable from 100kHz to 40MHz Secondary (load) encoder supported
MOTOR COMPATIBILITY	Requirements:	Rotary brush or 3-phase brushless rotary/linear motor
HALL SENSOR INPUTS	Specifications:	5k $\Omega$ pull-up to +5V
	Features:	Digitally filtered; used for setting torque vector upon initialization only; drive can also operate in Hall-less mode
DEDICATED INTERFACE	Interface:	5k $\Omega$ pull-up to +3.3VDC; digitally filtered
OUTPUTS	GPO-0, GPO-1	Isolated, short-circuit protected, open collector outputs. 47V (active) clamping for directly driving inductive loads. Requires external 4-28VDC power supply GPO-0 625mA GPO-1 208mA
INPUTS	GPI-0, GPI-1	High-speed, optically isolated, Response time < 200nS, Operating voltage 4-28VDC requires 10mA, Can be used as capture inputs
	GPI-2, GPI-3	Can be user-configured as limit switch inputs, TTL with 2k pull-up, digitally filtered
PROTECTION & SAFETY FUNCTIONS	Drive protection:	Short circuit (phase-to-phase, phase-to-ground), over temp, over voltage, over current, protected for open windings, fused.
	Motor protection:	True RMS torque limiting, automatic speed limit, motor jam detection, over temp
	Mechanical safeguards:	Hardstop detection, limit switch servoing, adjustable tracking error limits and shutdown thresholds, adjustable torque and speed limits
	Electrical Isolation:	6.0mm (0.236")
OTHER	+5VDC out of motor connector (encoder/hall power)	300mA max.
	Dual encoder support	Yes
INPUT SUPPLY	Input voltage/current: Main DC (bus) power supply	130-360VDC (derived from IPC @ 90-250VAC, single or 3-phase)
	Input current (max) Input current (typical)	15A RMS 5A RMS, application dependent
COUNTRY OF ORIGIN	Manufactured in:	USA

ISC-M603-KCX Specifications		
GENERAL	Dimensions, in (mm):	8.95 (227) x 6.40 (163) x 2.32 (59)
	Weight, oz (g):	53.5 (1515)
ENVIRONMENTAL	Temperature:	0-40°C
	Humidity:	0-90%, non-condensing
COMPLIANCE	Electrical safety:	EN 61010, UL508C
	EMI:	EN 61326
	Machine safety:	EN 954-1, with proper power control
INTERNAL FAN		No
OUTPUT POWER	Peak Current:	11A
	Continuous Current:	4A RMS
	PWM ripple frequency:	28kHz, center balance vector type
	Conversion Efficiency:	>99%
COMPENSATOR	TSPD:	35 $\mu$ S
	Position/Velocity control:	Enhanced PIV with proprietary velocity, acceleration and jerk estimators, Inertia Matching Technology (IMT), Regressive AutoSpline (RAS) and Anti-Hunt. Provides velocity, acceleration, jerk, and friction feed-forward gains
	Torque control:	Synchronous vector with DQ decoupling, SmartSaturation, and auto calibration
ENCODER	Interface:	Primary: Single-ended or differential, user selectable
	Features:	Bad sequence detection, digital filtering adjustable from 100kHz to 40MHz Secondary (load) encoder supported
MOTOR COMPATIBILITY	Requirements:	Rotary brush or 3-phase brushless rotary/linear motor
HALL SENSOR INPUTS	Specifications:	5k $\Omega$ pull-up to +5V
	Features:	Digitally filtered; used for setting torque vector upon initialization only; drive can also operate in Hall-less mode
DEDICATED INTERFACE	Interface:	5k $\Omega$ pull-up to +3.3VDC; digitally filtered
OUTPUTS	GPO-0, GPO-1	Isolated, short-circuit protected, open collector outputs. 47V (active) clamping for directly driving inductive loads. Requires external 4-28VDC power supply
		GPO-0 625mA GPO-1 208mA
INPUTS	GPI-0, GPI-1	High-speed, optically isolated, Response time < 200nS, Operating voltage 4-28VDC requires 10mA, Can be used as capture inputs
	GPI-2, GPI-3	Can be user-configured as limit switch inputs, TTL with 2k pull-up, digitally filtered
PROTECTION & SAFETY FUNCTIONS	Drive protection:	Short circuit (phase-to-phase, phase-to-ground), over temp, over voltage, over current, protected for open windings, fused.
	Motor protection:	True RMS torque limiting, automatic speed limit, motor jam detection, over temp
	Mechanical safeguards:	Hardstop detection, limit switch servoing, adjustable tracking error limits and shutdown thresholds, adjustable torque and speed limits
	Electrical Isolation:	6.0mm (0.236")
OTHER	+5VDC out of motor connector (encoder/hall power)	300mA max.
	Dual encoder support	Yes
INPUT SUPPLY	Input voltage/current: Main DC (bus) power supply	130-360VDC (derived from IPC @ 90-250VAC, single or 3-phase)
	Input current (max) Input current (typical)	15A RMS 5A RMS, application dependent
COUNTRY OF ORIGIN	Manufactured in:	USA

## APPENDIX B: GOLDEN RULES OF INSTALLATION

### POWER



1. Ground the Meridian ISC to the machine chassis or frame. Use unplated 10-32 screws to secure the case extrusion to the machine. Verify that the frame is connected to the machine's Protective Earth Terminal (safety ground).
2. Don't run the unit's power return through the machine's frame or chassis.



Note: The DC bus power—provided by the Amazon IPC power supply—is *not* referenced to ground. Both the positive and negative leads of the IPC carry hazardous voltages.

3. Daisy chaining power through the Meridian power connectors is safe and convenient. Full electrical isolation between the Meridian's power and control signals means that "star" power distribution is not required.
4. Use heavy gauge wire for power cables.

### GROUNDING AND SHIELDING



5. Use shielded cable for all control signal connections: the motor's encoder & commutation signals, optional connections and the I/O and limit cables. The encoder and controller cables should have low capacitance insulation. Low capacitance cable conductors are typically made from polyethylene, foamed polyethylene, Teflon<sup>®</sup>, FEP, etc.
6. Connect the control signal cable's isolated control ground to the machine frame or chassis only at a single point at the controller. Do not hook isolated control ground to the machine frame or chassis at any other location.
7. **Do not** ground the limit switch circuit to the machine frame or chassis.

### MOTOR CABLES



8. Use heavy gauge shielded cable for the motor phase wiring. Connect the shield to pin 1 on the Meridian's motor connector (case ground).
9. Don't ground the encoder cable shield to the motor case or allow it to touch the motor phase shield at any point.
10. Don't run the motor's commutation (Hall) signals through the motor phase cable at any point.



11. Don't run motor thermostat signals (if any) through the motor phase cable at any point.

---

## CABLE MAKING GUIDELINES

These guidelines, when followed carefully, will help minimize cable design and fabrication problems.

### GENERAL RECOMMENDATIONS

#### **1. Avoid cables made with hand tools.**

Hand crimping tools, when properly selected and used by a skilled operator, make good crimp connections. However, since these tools are expensive, typically \$200 - \$400 each, technicians rarely have the wide variety required to make proper crimps on all of the terminal types and wire sizes they encounter. Unfortunately, it's easy to use the wrong tool and not realize it, or even more likely, to use the wrong tool and think it's "probably OK". These hand tools are awkward, cumbersome to use and often require the operator to master a certain "feel". In addition, these hand tools don't have any built-in quality assurance features.

In certain instances, you may be forced to make a hand crimped cable, for example, when you're in a hurry for a custom length. If you do, be sure that you have the *exact hand tool and die* that the terminal manufacturer recommends (see below), perform a visual inspection to ensure that the insulation is captured in the terminal's strain relief and do a pull test on each connection before inserting it into the connector.

#### **2. Verify that your cable shop has all of the proper tools and equipment.**

Use a cable shop that has automated presses for wire termination and make sure they have the proper applicator "heads" (dies) for the exact terminals used. (If they don't, consider buying applicator heads for them). It's strongly preferred that they have presses with automatic "crimp height" checking as this in-process check is the main measure of termination quality. Making this 100% check without requiring human intervention is a key advantage. If they don't have these automatic crimp-height-checking presses, make sure their general procedures include checking the crimp height on first articles and periodically during a run of cables. Under no circumstances should you accept a shop using hand tools.

#### **3. Specify 100% electrical testing of all cables.**

Specify that cables and harnesses be 100% electrically tested, preferably with resistance tests. The cable shop should have automated equipment by CableScan, DynaLab, CheckSum, or other vendors for this purpose. The fixture cost for 100% electrical testing is low, ranging from \$0-\$200 per cable assembly, and it's definitely worth it.

#### **4. Be certain that all terminals are properly specified**

Check all your terminal specifications carefully. Research all of your drawings and make certain that the terminals specified can accept the necessary wire gauges. Also, look carefully at the insulation diameter range supported by each terminal. If the insulation diameter range on the terminal is incorrect for the wire used, the individual wire strain relief will be compromised and this can lead to premature failure. Make certain that the plating between mating terminals is the same. Using gold is great, but not if you are mating with tin. Use gold plated sockets with gold plated

pins and tin plated sockets with tin plated pins to avoid galvanic corrosion.

### 5. Prepare complete pictorial drawings.

Create drawings that are pictorial in nature (i.e. visually representative of the subject). Include fabrication details such as jacket strip lengths, shield termination details, cable tie locations, marking details, etc. The more call-outs, detail views, and exploded views, the better. Visual communication is critical here. Don't leave the details to the cable shop as "best practices" vary *widely* from shop to shop. Include the complete BOM right on the drawing. Finally, make the end-to-end cable length easy to modify. This may help reduce future drawing effort if you need similar cables of varying length at some point in the future.

## A NOTE ON HAND CRIMP TOOLS

When necessary, quality cables can be made with hand tools, provided that manufacturer's guidelines are faithfully adhered to. An excellent web-based resource on this subject is the Molex document "Good Crimps and How to Recognize Them", found in the Tech Library section of the Molex website. [Click here](#) for a direct link. This collection of crimp-specific reference information includes how to identify good and bad crimps as well as best practices and specifications for crimp techniques and tooling.



**Note:** Though similar in appearance, each type of crimp terminal requires a specific handset and die set. Failure to use the proper tool, die set, or terminal for the job will result in poor quality terminations and premature cable harness failures.



**Note:** Cable failures due to poor crimp quality are the most common mode of failure for OEM machine manufacturers and their customers.

# APPENDIX C: CONNECTOR REFERENCE FOR MODELS M6xx/7xx

J1 – Control Connector	Pin	Signal Name	Mates With
<p>WIRE ENTRY VIEW</p>	1	Chassis	<p><b>CONNECTOR</b> AMP/207464-7</p> <p><b>CONTACTS</b> AMP/745254-2 (22-26 AWG)</p> <p><b>HOOD</b> AMP/206478-3</p> <p><b>CRIMP TOOL</b> AMP/58448-2</p> <p><b>PIN EXTRACTOR</b> AMP/91285-1</p>
	2	Load Encoder A (in)*	
	3	Load Encoder B (in)*	
	4	Load Encoder I (in)*	
	5	GPI-2/+Limit	
	6	+5V Out	
	7	+5V Out	
	8	+5V Out	
	9	+5V Out (Encoder)	
	10	GPI-0	
	11	GPI-1	
	12	Vo+	
	13	Vo+	
	14	Load Encoder A~ (in)*	
	15	Load Encoder B~ (in)*	
	16	Load Encoder I~ (in)*	
	17	GPI-3/-Limit	
	18	GND	
	19	GND	
	20	GND (Encoder)	
	21	GPI-0 Return	
	22	GPI-1 Return	
	23	Vo-	
	24	GPO-1	
	25	GPO-0/Brake	

\*Secondary encoder not supported by ISC-M6xxx series units

P3, P4 Power Connector	Pin	Signal Name	Mates With
<p>WIRE ENTRY VIEW</p>	1	V+	<p><b>CONNECTOR</b> Molex/42816-0312</p> <p><b>CONTACTS</b> Molex/42815-0011-C (12 AWG)</p> <p><b>CRIMP TOOL</b> Molex/63811-1600</p> <p><b>PIN EXTRACTOR</b> Molex/63813-0400</p>
	2	V-	
	3	Chassis/Shield GND	

P5-A Motor Encoder	Pin	Signal Name	Mates With
<p>WIRE ENTRY VIEW</p>	1	Gnd	<p><b>CONNECTOR</b> Molex/39-01-2140</p> <p><b>CONTACTS</b> Molex/39-00-0047 (24 AWG)</p> <p><b>CRIMP TOOL</b> Molex/638190900 (16-24 AWG)</p> <p><b>PIN EXTRACTOR</b> Molex/11-03-0044</p>
	2	Encoder I~	
	3	Encoder B~	
	4	Encoder A~	
	5	Gnd	
	6	Comm. T-R	
	7	Mtr. Thermostat in	
	8	Chassis	
	9	Encoder I	
	10	Encoder B	
	11	Encoder A	
	12	+5V Out	
	13	Comm. R-S	
	14	Comm. S-T	

P5-B Motor Phases	Pin	Signal Name	Mates With
<p>WIRE ENTRY VIEW</p>	1	Motor Phase Shield	<p><b>CONNECTOR</b> Molex/44441-2004</p> <p><b>CONTACTS</b> Molex/43-375-0001 (14-18 AWG)</p> <p><b>CRIMP TOOL</b> Molex/638117200 (14-18 AWG)</p> <p><b>PIN EXTRACTOR</b> Molex/638132700</p>
	2	Motor Phase T	
	3	Motor Phase S	
	4	Motor Phase R	

**Teknic Incorporated**

115 Victor Heights Pkwy  
Victor, NY 14564

Copyright © 2018 Teknic Inc. All rights reserved.

TEKNIC, INC.