



CLEARPATH-IP MOTORS

DC INPUT, FRACTIONAL HORSEPOWER, IP53-RATED

MODELS IPVC, IPHP, AND IPSK

NEMA 23 AND NEMA 34 FRAME SIZES

VERSION 1.12 NOVEMBER 14, 2025

THIS PAGE INTENTIONALLY LEFT BLANK

TABLE OF CONTENTS

TABLE OF CONTENTS	3
TOP TIPS FOR CLEARPATH-IP USERS	6
INTRODUCTION	7
What is ClearPath-IP?	7
SAFETY WARNINGS	9
Personal Safety Warnings.....	9
CE Compliance Warnings.....	9
General Disclaimer	10
QUICK START GUIDE	11
Parts of a ClearPath-IP Motor	11
Parts of an I/O HUB	12
Spinning Your ClearPath-IP Motor	13
Connect the Components	13
Install ClearView 3.0 Software	13
Test DC Bus Power Polarity.....	14
Test Spin Your ClearPath-IP Motor	16
POWERING CLEARPATH-IP MOTORS	17
Before Powering a ClearPath-IP Motor.....	17
Direct Power Connection.....	17
Power Distribution Boards	18
POWER4-STRIP	18
POWER4-HUB	19
Logic Power Supply (24VDC)	23
I/O HUB	24
Introduction.....	24
Parts of an I/O HUB	25
Main Connectors.....	25
I/O HUB Models and Features.....	26
I/O HUB Model Numbers	26
Table of I/O HUB Features by Model	26
Powering an I/O HUB	29
Tools and Parts Required:	29
Wiring Instructions.....	29
Teknic 24VDC Power Supply.....	30
Setting The I/O HUB IP Address	30
I/O Wiring.....	31
Digital Inputs: Switches, NPN Logic Devices.....	32
Digital Inputs: PNP Logic Devices	32
Digital Outputs: GPIO (Push-Pull, PWM)	33
Digital Outputs: Motor I/O (Brake Output).....	33
Digital Outputs: Open-Collector (3.3V and 5V Inputs) ..	34
Analog Inputs: Potentiometer, Transducer	35
Analog Outputs: Various	36
Encoder Input	37
SOFTWARE (CLEARVIEW 3.0)	38
Minimum System Requirements.....	38

Download Link.....	38
APPENDIX A: TROUBLESHOOTING	39
LED Codes: ClearPath-IP Motor	40
LED Codes: I/O HUB Status LED and Info LED	41
LED Codes: MNS LED.....	42
LED Codes: POWER4-HUB	43
APPENDIX B: MECHANICAL INDEX	44
Dimensional Drawings	44
ClearPath-IP Motors.....	44
I/O HUB and DIN Rail Mount	44
Power Distribution Boards	44
Fan Mounting	45
Motor Mounting, Thermal Considerations	46
Connecting ClearPath-IP to a Mechanical System.....	47
Motor Connection: General Tips and Guidelines.....	47
Notes on Coupling Selection.....	49
Installing Pulleys and pinions	50
About End-of-Travel Stops.....	51
Hard Blocks.....	51
Elastomeric (rubber) Stops.....	51
Pneumatic (dashpots).....	51
End Stops and Hard Stop Homing.....	51
APPENDIX C: MATING CONNECTORS AND CABLES	52
Mating Connectors.....	52
Cable Drawings	53
Control Cable: CPM-CABLE-CTRL-MU120.....	53
Control Cable: CPM-CABLE-CTRL-MM660	53
Power Cable: CPM-CABLE-PWR-MM660	53
Power Cable: CPM-CABLE-PWR-MS120	53
Power Cable: PC-SBR-72	53
Network Cable: CABLE-CAT5-120	53
APPENDIX D: SPECIFICATIONS	54
ClearPath-IP Motor: Common Specifications.....	54
I/O HUB Specifications	55
POWER4-HUB Specifications.....	56
APPENDIX E: GROUNDING AND SHIELDING.....	57
Protective Earth (PE) Connection	57
Grounding and Shielding.....	57
Power Returns.....	58
APPENDIX F: CIRCUIT SCHEMATICS.....	59
POWER4-HUB Schematic (simplified).....	59
APPENDIX G: MOTOR PART NUMBER KEY	60
APPENDIX H: MISCELLANEOUS TOPICS	61
Power Supply Notes.....	61
Teknic IPC-3 and IPC-5 Power Supply Overview	61
DC Bus Power Supply Switching and Fusing	61
IPC-3 and IPC-5 Thermal Derating Data	62
How to Make an Inexpensive 24V Logic Supply Cable.....	63

Other Product Notes63
 Re: Electrical Fast Transient (EFT) Testing.....63
 ClearPath EMC Instructions.....63

TOP TIPS FOR CLEARPATH-IP USERS

These tips apply to the fractional horsepower ClearPath-IP motors covered in this document.

TOP TIPS

- ✓ **Never reverse DC bus power polarity to your ClearPath motor. Doing so will damage the motor permanently.**
- ✓ **Noise at first enable?** The brief buzzing sound you hear the first time your motor is enabled after power up is the motor initializing itself. This is normal (and necessary).
- ✓ **Use a properly rated USB cable.** Use high-speed USB data cables to communicate with your ClearPath motor. Charging cables that have only 5VDC and ground won't work.
- ✓ **Protect the motor's USB connector.** Avoid yanking or tripping over a USB cable connected to your ClearPath motor. A damaged USB connector will prevent serial communication between the motor and setup software.
- ✓ **Cover the motor's USB port when it (the port) is not in use.** Use the included silicone plug to keep dust and debris out of your motor's USB port.
- ✓ **Auto-Tune on fully loaded mechanics.** Auto-Tune with your motor connected to the axis mechanics exactly as it will be during normal operation. The default motor tuning file is for unloaded use only.
- ✓ **Use a dedicated power supply for your ClearPath-IP motors.** Do not power ClearPath motors from the same supply used to power your PLC, I/O HUB or other sensitive electronics.

INTRODUCTION

WHAT IS CLEARPATH-IP?

ClearPath-IP is a multi-axis servo motion control and I/O system that is fully compliant with the EtherNet/IP™ communication protocol¹.

ClearPath-IP motors are brushless DC servomotors with custom rare-earth magnets, a powerful servo drive, and a high-resolution optical encoder, featuring advanced EtherNet/IP™ firmware, all in a package about the size of a typical non-integrated motor.

The I/O HUB serves as the interface between your EtherNet/IP™ network and ClearPath-IP motors. It supports up to 4 axes of motion and up to 13 points of configurable I/O. The I/O complement can include NPN and PNP limit switches, home sensors, stop sensors, analog I/O, spring-applied brakes, relays, GPIO, external encoder input and more.

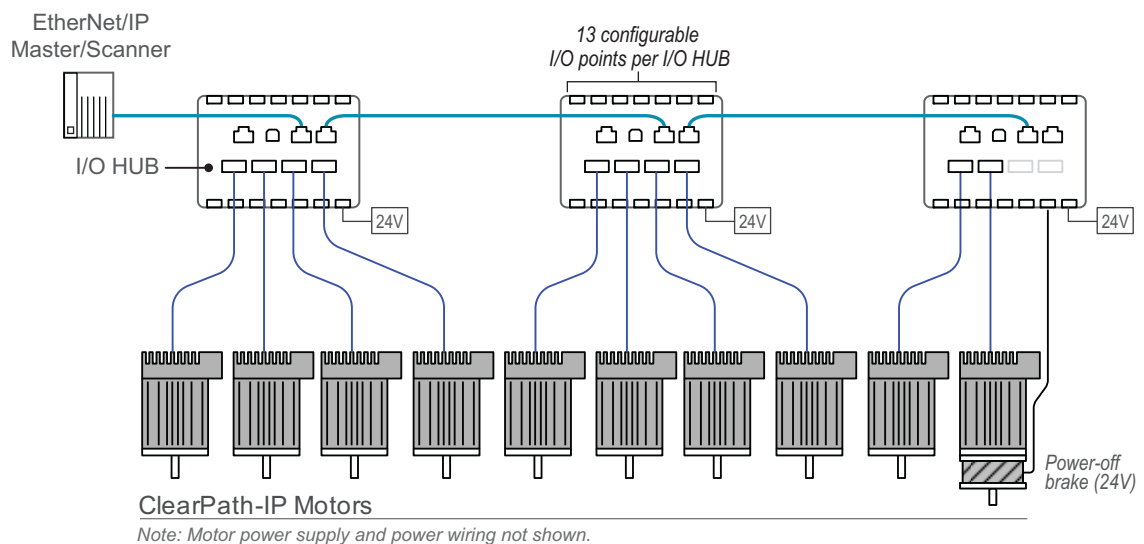

Example ClearPath-IP network.

ClearPath-IP is a rugged, industrial-grade product. The motor subsystem is based on Teknic's [Hudson family](#) of brushless servo motors, with similar instrument grade bearings, stainless steel shaft, windings, rare earth magnets, and encoder technology. The drive electronics and advanced motion control firmware bring smooth, accurate, and responsive motion to EtherNet/IP™-based automation projects.

Easy setup. Install ClearView 3.0 software, connect ClearPath to your PC via USB, and run the included auto-tune software to optimize servo performance for your mechanical system. I/O Hub setup and network configuration typically take just a few minutes. Once you're up and running, Teknic's motion AOIs (Add-On Instructions) simplify and streamline application development.

ClearView 3.0 software features an intuitive user interface that allows users to quickly change motor settings, assign I/O functions, and test

¹ EtherNet/IP™ is a trademark of ODVA, Inc.

motors and mechanics using only ClearView's built-in Move Generator and Software Scope.

Teknic's IP-Sync® technology provides exceptionally tight motor-to-motor synchronization. Most EtherNet/IP™ networks update in the millisecond range. ClearPath-IP motors can now achieve synchronization in the 200 nanosecond range as a result of Teknic's IP-Sync technology. This feature can give machine builders a noteworthy performance advantage on high-speed, coordinated multi-axis systems.

Safety and self-protection features are standard. ClearPath-IP will rapidly shut down if it becomes overloaded, overheated, detects a hard stop, or exceeds any of the safety and motion limits you specify.

Made in USA. Each ClearPath-IP motor and I/O HUB is built and tested in our New York manufacturing facility, so you can be certain you're purchasing a high quality, fully tested motion control product right out of the box. And, Teknic backs up each ClearPath-IP motor with a three-year warranty.

SAFETY WARNINGS

IMPORTANT: Read this manual before attempting to install, power up, or operate a ClearPath motor. Failure to understand and follow the safety information presented in this document could result in a serious injury to humans and property.

Always use caution and common sense when handling motion control equipment. Even the smallest ClearPath motor is powerful enough to crush fingers, tear off a shirt sleeve, or pull out a patch of hair faster than the blink of an eye². These devices are extremely powerful and **dangerous if used carelessly.**

PERSONAL SAFETY WARNINGS

- Do not wear loose clothing or unconfined long hair when using ClearPath-IP motors. Remove ties, rings, watches and other jewelry before operating an unguarded motor.
- Do not operate a ClearPath-IP motor if your alertness, cognitive function, or motor skills are impaired.
- Avoid carrying a ClearPath-IP motor by its cable.
- Always understand how to use ClearPath-IP software controls and associated features before attempting to power, enable, or otherwise operate a ClearPath-IP motor.
- Install and test all emergency stop devices and controls before using ClearPath-IP.
- Before applying DC power, secure the ClearPath-IP motor to a stable, solid work surface and install a finger-safe guard or barrier between the user and the motor shaft.
- Provide appropriate space around the ClearPath-IP motor for ventilation and cable clearances.
- Do not allow cables or other loose items to drape over, or rest near the ClearPath-IP motor shaft.
- Never place fingers, hands, or other body parts on or near a powered ClearPath-IP motor.
- Thoroughly test all ClearPath-IP applications at low speed to ensure the motor, controls, and safety equipment operate as expected.

CE COMPLIANCE WARNINGS

- There are no user serviceable parts inside.
- Follow all instructions and use the product only as directed.

² A single blink of the human eye takes between 100 and 400 milliseconds according to the *Harvard Database of Useful Biological Numbers*.

- The safety of any system incorporating this equipment is the responsibility of the system designers and builders.
- The machine designers need to recognize and incorporate required warning symbols, guards and shields for ClearPath-IP motors that are used in applications that can result in the externally accessible parts of their machine exceeding a temperature of 65 Celsius. This is required to reduce the possibility of burns. A tool shall be required to remove any guards and/or shields.
- ClearPath-IP motors require that a path exist between the motor chassis and the Protective Earth (PE) connection of the machine to which it is affixed. (Note: The PE connection is often satisfied by simply bolting the motor to the machine; however it is the users responsibility to verify the PE connection.) If an external grounding wire is required, use the same or larger wire gauge as used between the DC power supply and ClearPath Motor.
- Any maintenance or repair guide created by the user shall state that power shall be removed before the Protective Earth ground conductor is disconnected. When reconnecting power, the Protective Earth ground conductor shall be the first wire reconnected. Main power may be reconnected only after the Safety Ground connection is secure.
- When the ClearPath-IP motor is mounted in an application where the shaft end is higher than the electrical connection end of the motor, the USB connector plug provided by Teknic must be installed. The USB plug in these installations becomes an element to prevent the spread of fire per EN 61010-1 section 9.3.2 part c.

GENERAL DISCLAIMER

The User is responsible for determining the suitability of products for their different applications. The User must ensure that Teknic's products are installed and utilized in accordance with all local, state, federal and private governing bodies and meet all applicable health and safety standards.

Teknic has made all reasonable efforts to accurately present the information in the published documentation and shall not be responsible for any incorrect information which may result from oversights. Due to continuous product improvements, the product specifications as stated in the documentation are subject to change at any time and without notice. The User is responsible for consulting a representative of Teknic for detailed information and to determine any changes of information in the published documentation.

If Teknic's products are used in an application that is safety critical, the User must provide appropriate safety testing of the products, adequate safety devices, guarding, warning notices and machine-specific training to protect the operator from injury.

QUICK START GUIDE

This section covers:

- Parts of a ClearPath-IP motor and I/O HUB
- ClearView 3.0 software installation
- How to establish a USB connection between a ClearPath-IP motor and PC running ClearView 3.0
- How to spin a ClearPath-IP motor using ClearView 3.0. I/O HUB setup is not discussed in this section.

PARTS OF A CLEARPATH-IP MOTOR

The ClearPath-IP motor is an industry-leading, brushless servo motor with precision optical encoder, servo compensator, and torque drive. The CPM-IP motor and I/O HUB integrate readily with existing EtherNet/IP™ systems to bring ClearPath quality motion and I/O to this popular industrial control architecture.

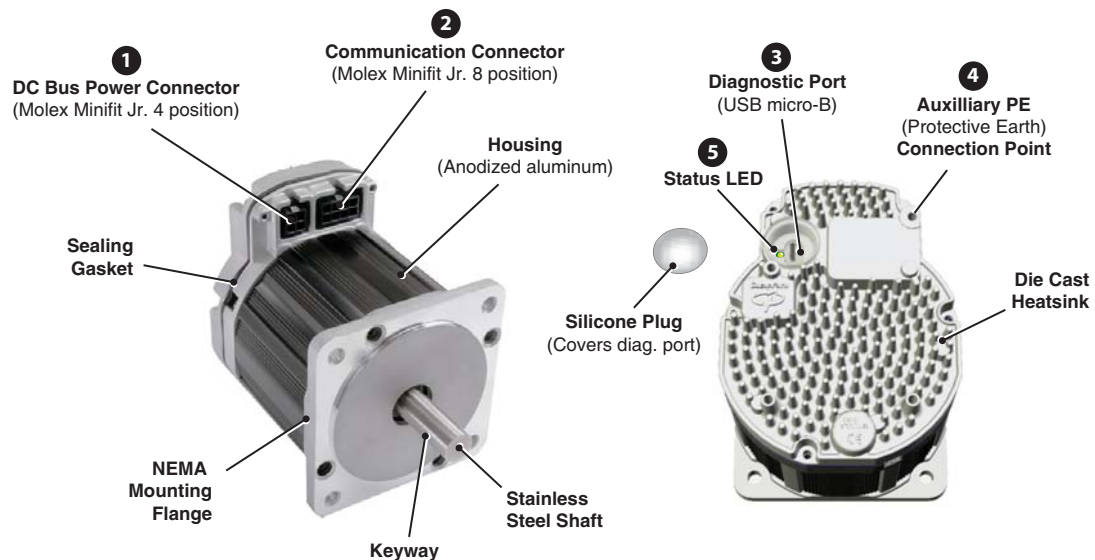

1) DC Bus Power Connector

- Function: Input for main DC motor power (24-75VDC).
- Connector type: 4-pin Molex Minifit Jr.

2) Communications Connector

- Function: Carries communication signals to and from ClearPath-IP motors.
- Connector type: 8-pin Molex Minifit Jr.

3) Diagnostic Port

- Function: Connect ClearPath-IP to an optional laptop or PC with a standard USB cable (Type A to Micro-B). For use with ClearView 3.0 configuration and diagnostic software.
- Connector type: USB Micro-B (female)

4) Auxiliary Protective Earth Connection Point

- Use this unthreaded screw boss to connect your motor to Protective Earth ground if the motor is not otherwise bonded to PE through the machine frame or other means.

5) Status LED

- Function: Indicates operational status of ClearPath-IP. LED codes are explained in Appendix A.

PARTS OF AN I/O HUB

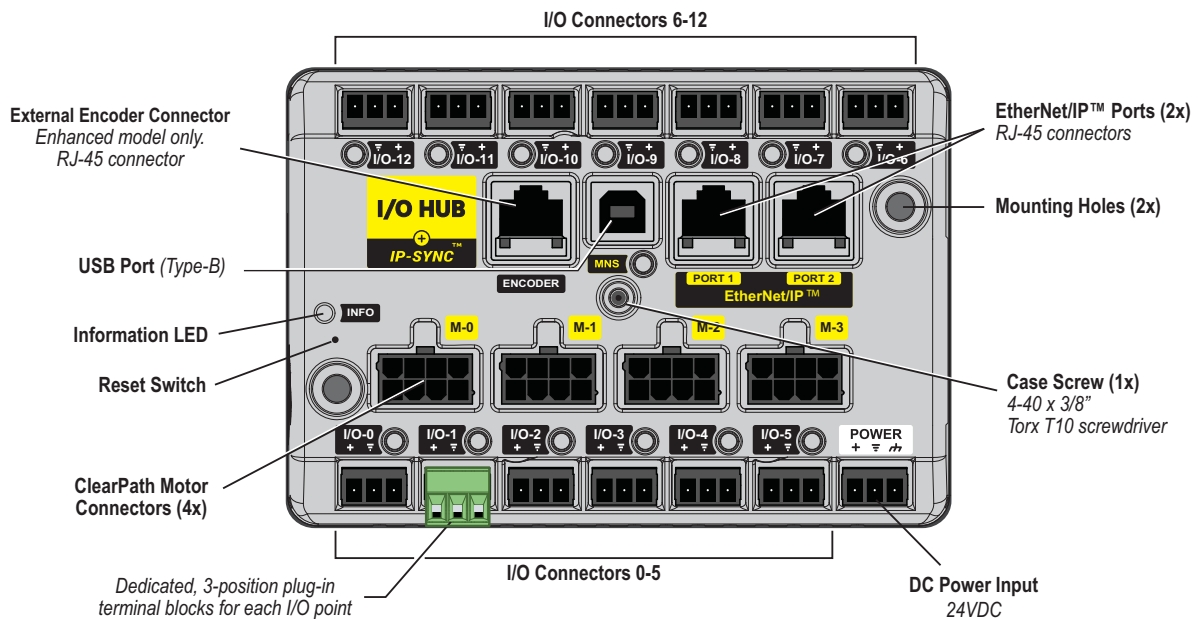

SPINNING YOUR CLEARPATH-IP MOTOR

This section describes how to power up and spin a ClearPath-IP motor under ClearView 3.0 software control using just a motor, power supply, and a few cables (i.e., *without* a master PLC or I/O HUB).

CONNECT THE COMPONENTS

- Remove AC power to your motor's DC Bus Power Supply.
- Connect the power cable to your ClearPath-IP motor in one of the configurations shown below. **Important:** Do not connect a live cable to your motor as this can damage the connector pins on the motor and the cable.
- **Note:** POWER4-HUB wiring not shown below. Click [here](#) for POWER4-HUB power connection details.

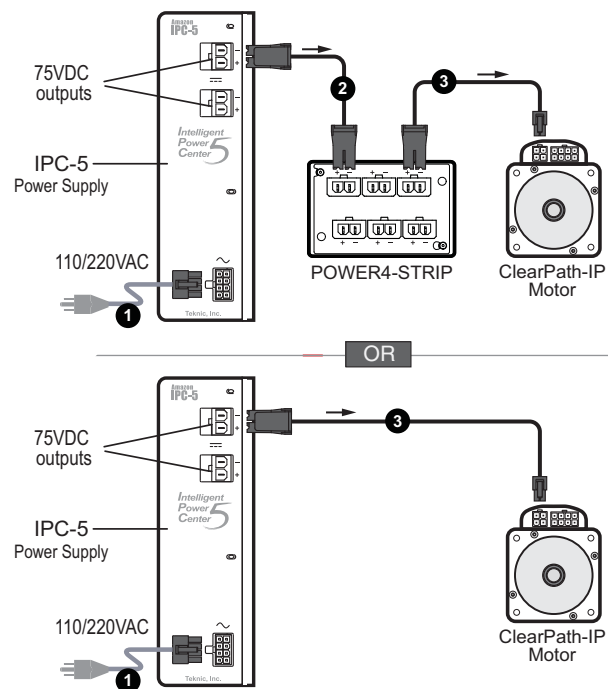

Ref.	Part Number	Description
1	IPC35-CABLE110	AC Line Cord for IPC-3 and IPC-5 power supply. Standard 110VAC plug to Minifit Jr. 8-pin connector. 78.25". (Cable comes with supply.)
2	PC-SBR-72	Power cable, Sabre to Sabre, 72".
3	CPM-CABLE-PWR-MS120	ClearPath power cable. MiniFit Jr.4-pin to Sabre 2-pin, 120".

INSTALL CLEARVIEW 3.0 SOFTWARE

To download and install ClearView 3.0, click [here](#).

TEST DC BUS POWER POLARITY

DAMAGE WARNING: Never reverse DC Bus power polarity to a ClearPath motor. Doing so will permanently damage the motor.

Before applying DC bus power to your motor, please perform this quick polarity test, particularly if your cables *were not* made by Teknic.

1. Ensure the ClearPath-IP motor's power connector is disconnected, then apply AC power to the DC bus power supply (Teknic IPC-5, shown below).
2. With a multimeter set to DC volts, measure the voltage from V+ to GND. See diagram below for pin locations. You should measure a *positive* value of DC voltage. The actual voltage depends on the power supply used. **If you measure a negative value, the polarity is reversed. Please correct the polarity and measure again.**
3. Remove power from the supply.
4. Connect the power connector to your ClearPath-IP motor and turn on the power supply.

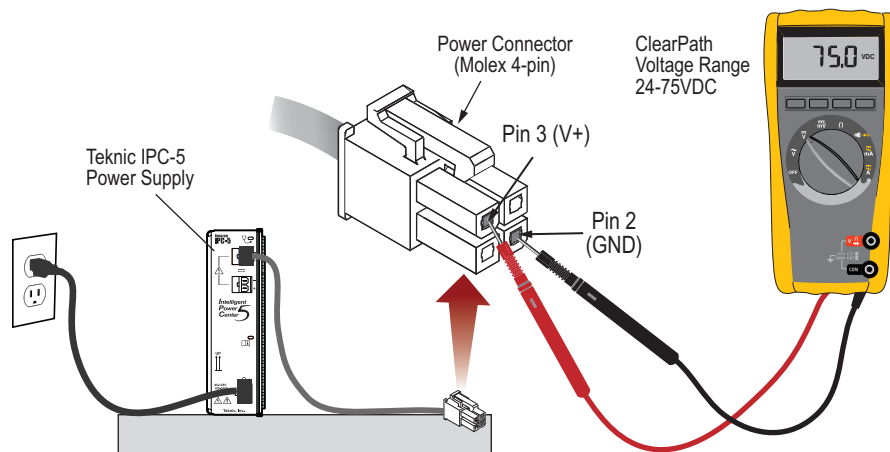

Testing polarity of DC Bus Power Supply

Before operating a ClearPath-IP motor.

- Secure the motor to a stable surface with a clamp or vise.
- Keep loose clothing, long hair, and cables away from the motor shaft.
- Avoid touching the motor's exposed connector pins.
- **Avoid hot swapping the power connector.** (i.e. don't insert or remove DC power connectors when the DC Bus Supply is powered up). This will progressively damage the connector terminals over time.

Establish communication

1. Power up your ClearPath-IP motor. The motor LED will be on if power is applied.
2. Connect a USB cable (type A to micro B) from the motor's rear USB port to your PC.

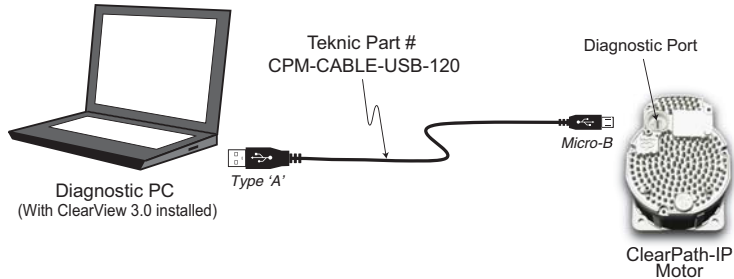

3. Open ClearView 3.0 software.
4. ClearView 3.0 will attempt to auto-detect your motor. Once detected, your motor will appear in the UI device list at right.

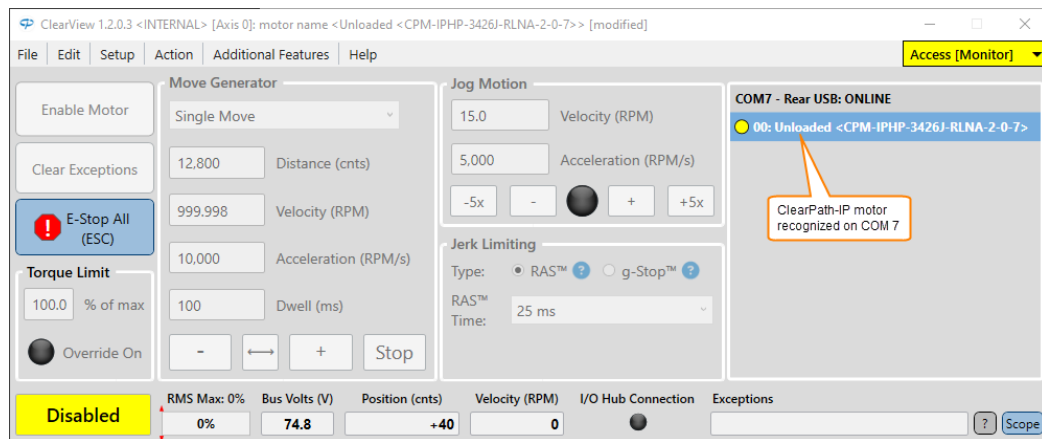

ClearPath-IP motor recognized in ClearView 3.0

5. If ClearView 3.0 **does not** find your motor, choose *File>Preferences and Port Select* and click "Auto-Detect Ports", or use the "First" drop down menu to select your motor from the list.

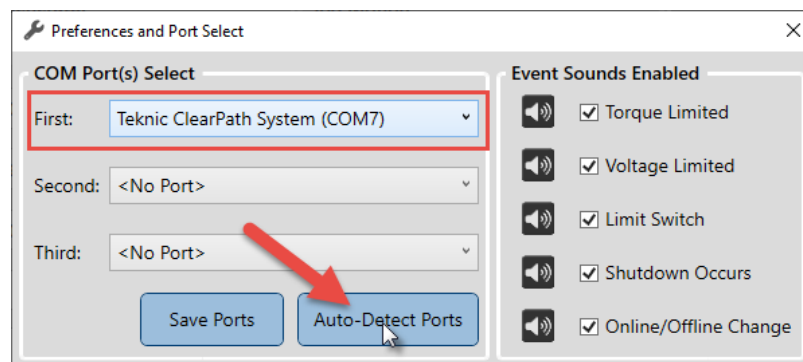

TEST SPIN YOUR CLEARPATH-IP MOTOR

Note: This section describes how to spin an unloaded motor only. ClearPath-IP motors ship pre-configured for *unloaded use*. **Always run the Auto-Tune application whenever you connect your motor to a different mechanical system.**

Click and spin—no PLC required. Once your system is powered up and communicating, you can take your motor for a test spin using the Move Generator controls in ClearView 3.0. Here's how:

1. Set the Access Level to "Full". The controls won't work otherwise. Tip: Remember to set the Access Level back to "Monitor" before commanding motion through a Master/Scanner.
2. Select a Move Type. Choose from: Back and Forth, Single, or Repeating Moves.
3. Enter the Move Parameters: Distance, Velocity, Acceleration, and Dwell (Dwell is the rest period between repeating moves).
4. Click Enable/Disable button once to enable the motor.
5. Click "Start Motion" (+ or -) button. Use "+" to start motion in the CCW direction (looking into the motor shaft). Use "-" to start motion in the CW direction.
6. Single click the "Stop" button to end motion cycling. Double click the Stop button to stop motion immediately.
7. Click "E-Stop All" or Esc key to stop motion immediately.

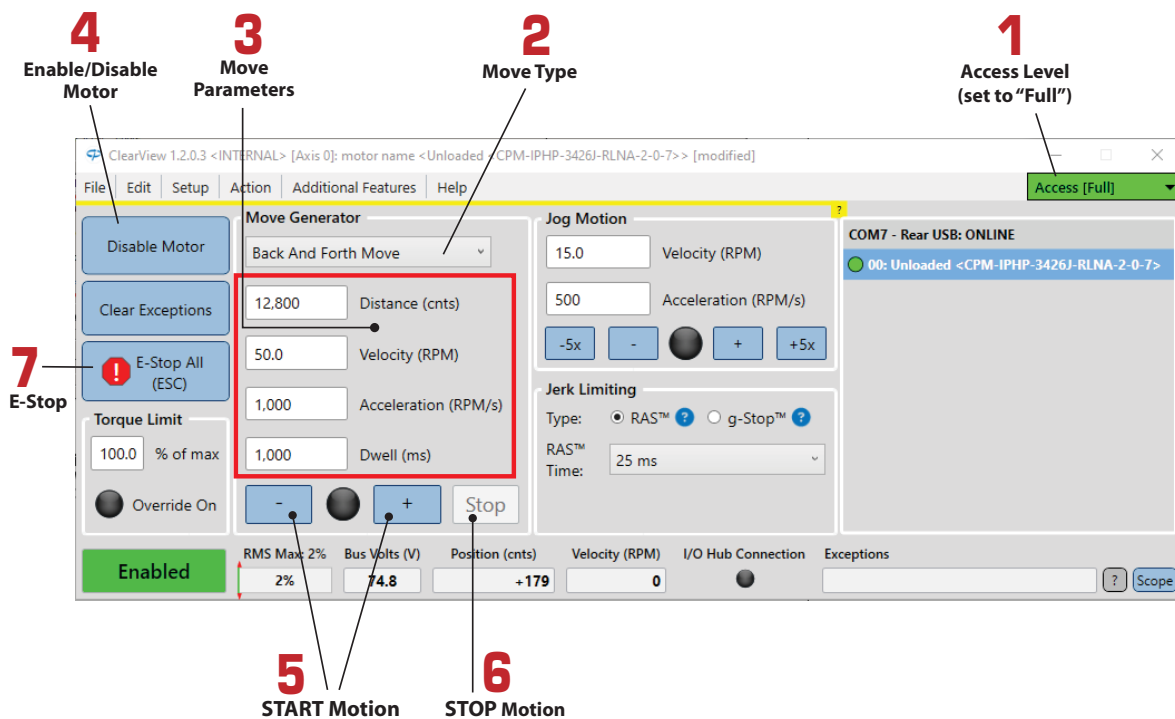

ClearView 3.0 Main UI

POWERING CLEARPATH-IP MOTORS

This section describes how to power ClearPath-IP motors.

BEFORE POWERING A CLEARPATH-IP MOTOR

IMPORTANT: Never reverse DC power to a ClearPath motor. Permanent damage will occur.

- Check for proper DC bus power polarity.
- Turn off the power supply before connecting or disconnecting the motor's power cable. Connecting and disconnecting the motor from a live power supply will cause electrical arcing that will damage the connectors.
- Never connect a ClearPath-IP motor to an AC outlet. This will irreversibly damage the ClearPath-IP motor.
- When a ClearPath-IP motor is first enabled after power up, the vector initialization algorithm will make a brief buzzing sound and the shaft may move slightly (1-4 degrees typical).

DIRECT POWER CONNECTION

One or two motors can be connected directly to an IPC-3 or IPC-5 power supply as shown below. To connect more than two motors, use a POWER4-HUB or POWER4-STRIP described later in this section.

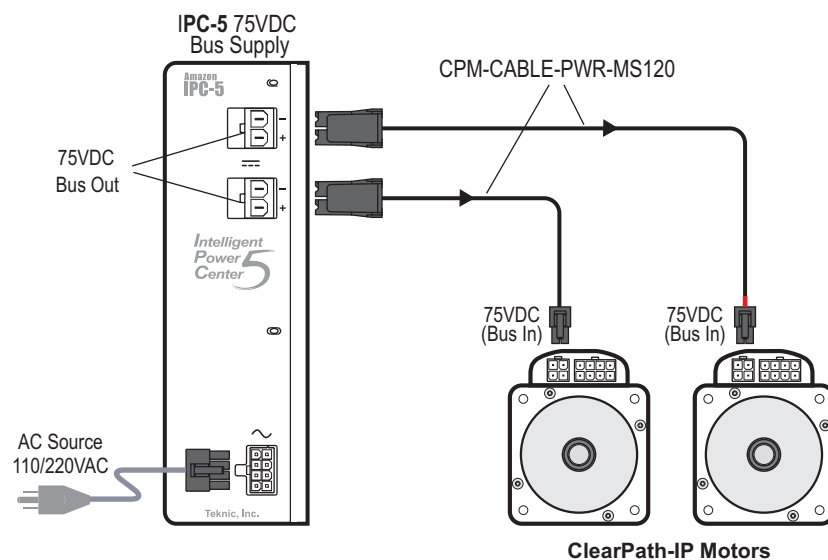

ClearPath-IP direct DC bus power connection

POWER DISTRIBUTION BOARDS

POWER4-STRIP

The **POWER4-STRIP** is a simple power distribution board with no active components. It is made up of six Molex Sabre-2 connectors wired in parallel.

To use the **POWER4-STRIP**, connect main motor bus power (24-75VDC) to any of the six connectors on the board. The remaining five connectors then become DC outputs. See figure below.

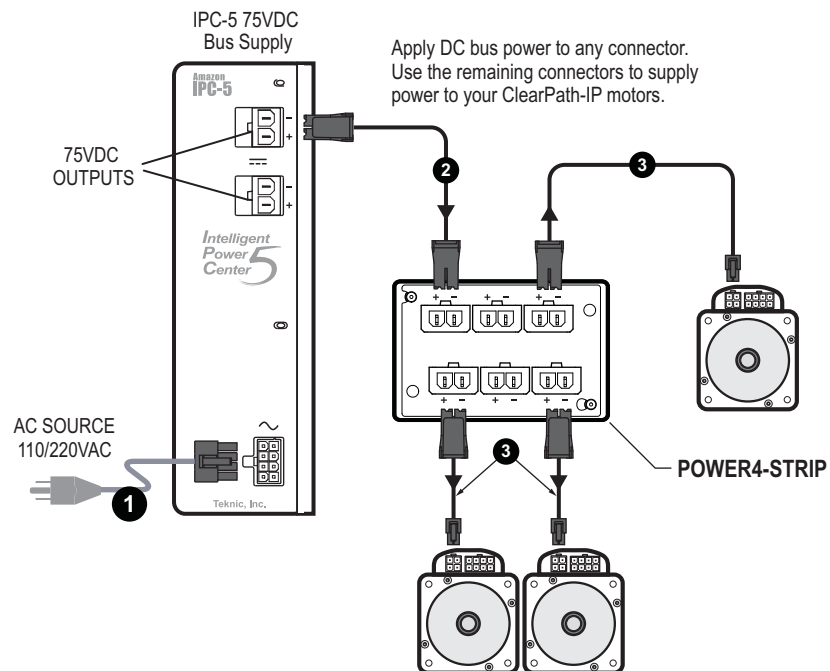

Ref.	Part Number	Description
1	IPC35-CABLE110	AC Line Cord for IPC-3 and IPC-5 power supply. Standard 110VAC plug to Minifit Jr. 8-pin connector. 78.25". (Cable comes with supply.)
2	PC-SBR-72	Power cable, Sabre to Sabre, 72".
3	CPM-CABLE-PWR-MS120	ClearPath power cable. MiniFit Jr.4-pin to Sabre 2-pin, 120".

POWER4-HUB

The **POWER4-HUB**:

1. Supplies DC bus power to as many as four ClearPath motors.
2. Delivers low voltage (24V) **logic backup power** to your ClearPath motors. Logic power keeps the motor's processor alive in the event of main bus power loss. This translates to uninterrupted communication, continuous status monitoring, and retention of encoder position.

Note: Logic backup power, on its own, cannot be used to spin a motor. Main DC bus power must be present to spin motors.

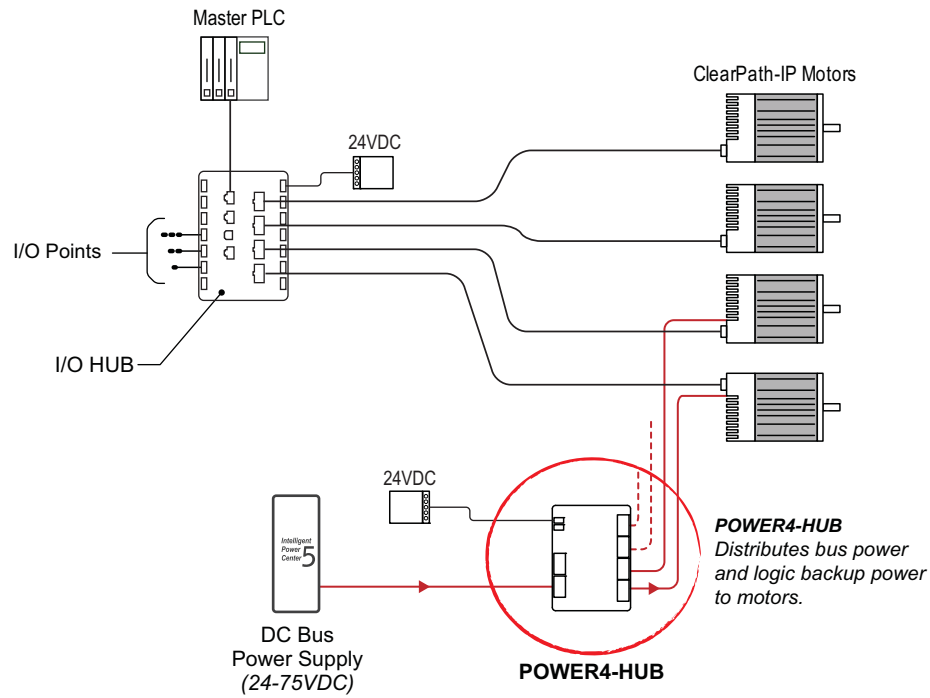

POWER4-HUB in a ClearPath-IP system

POWER4-HUB: THINGS TO KNOW

- **POWER4-HUB LED codes** are located in [Appendix A](#).
- **Logic backup power is not designed to spin motors.** It is designed to maintain uninterrupted, low voltage power to the motor electronics (encoder, DSP, communication, I/O, and associated circuits).
- **Damage Warning: Reversing DC bus power polarity to the POWER4-HUB will permanently damage it.** Use a meter to verify correct DC bus power polarity before connecting the power supply to the POWER4-HUB.
- **Do not "hot swap" DC power connectors.** Turn off DC bus power supply before connecting a motor to the POWER4-HUB. *Connecting and disconnecting the motor from a live power supply will cause electrical arcing that will damage the connectors over time.*
- **Logic backup power should not be used as a means of switching DC bus power on and off.** To control DC bus power, use a contactor on the AC side of the DC bus power supply.
- **Do not connect more than two POWER4-HUBs to a power supply.** Continuous and peak current usage must not exceed the power supply's specifications.

It is the user's responsibility to ensure that the DC bus power supply has sufficient continuous and peak power to meet their application requirements.

POWER4-HUB: COMPLIANCE NOTES

- Any 3rd party (non-Teknic) power supply used with the POWER4-HUB, should be current limited or fused to 25A or less using 25A, 300VDC (UL Listed) fuses.
- If UL compliance is a consideration, select a DC, UL Listed fuse.
- For those seeking a Class G fuse, the **SC-25 from Eaton Cooper Bussmann**, or **OSLCO25 from Littelfuse** is recommended. Fuse holders (also rated this way) include the **HPS-FF and TCFH30N (from ECB/Littelfuse respectively)**.

PARTS OF A POWER4-HUB

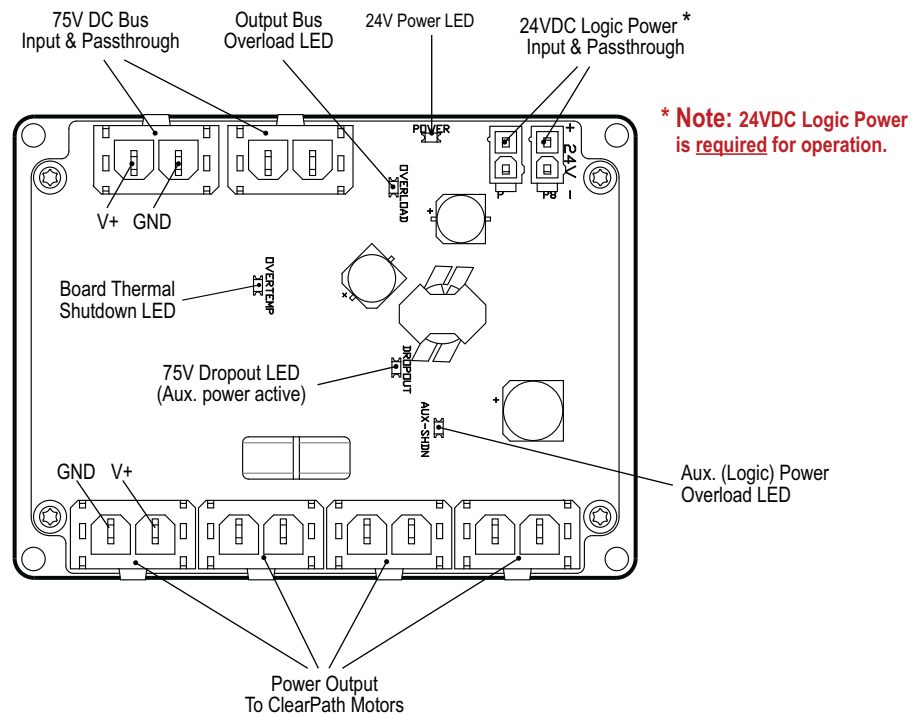

Parts of a POWER4-HUB

DC Bus Power Input/Pass-through (Qty. 2) - Supply 24-75VDC power from your DC Bus Supply to either of these connectors (they are wired in parallel). The other connector can be used to daisy chain bus power to a second POWER4-HUB if desired, or left unconnected.

IMPORTANT: Never connect two IPC-3/-5 power supplies to a single POWER4-HUB. These power supplies are not designed to operate in parallel or series configurations.

DC Bus Power Outputs (Qty. 4) - These four connectors supply bus power to your motors. In addition, if power is dropped, they carry aux. power to keep maintain motor communication to the host application. They are fully short-circuit protected.

24VDC Logic Power Input, with Passthrough (Qty. 2) - Supply low power 24VDC logic power to either of these connectors (they are wired in parallel). The other connector can be used to daisy chain power to a second POWER4-HUB.

POWER4-HUB LEDs - There are 5 LED indicators on a POWER4-HUB. Please refer to [Appendix A](#) for LED blink codes.

SINGLE POWER4-HUB SYSTEM

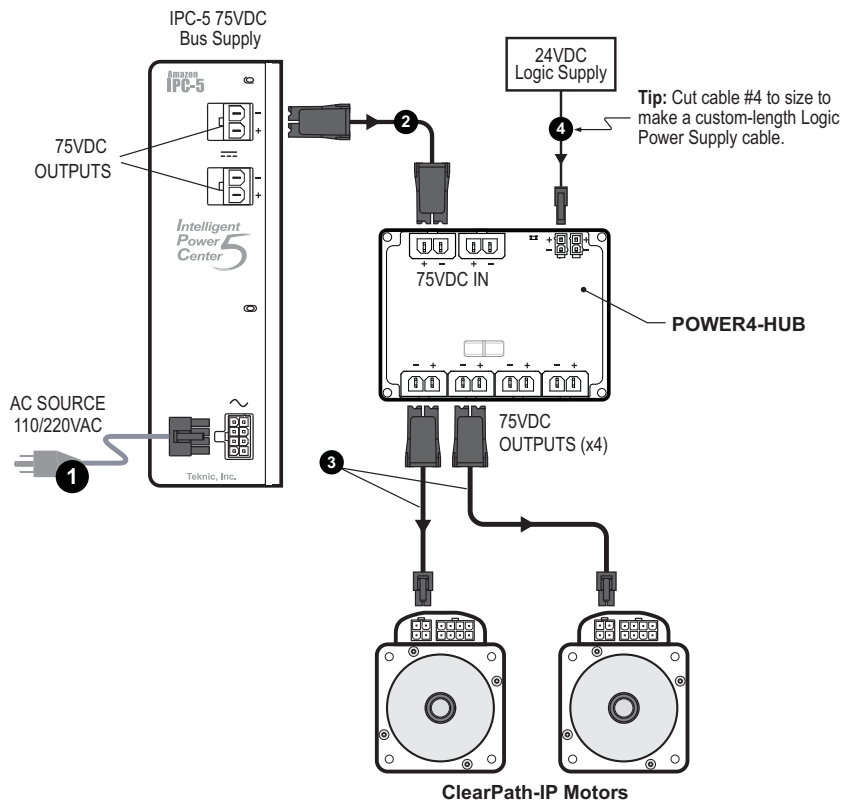

Ref.	Part Number	Description
1	IPC35-CABLE110	AC Line Cord for IPC-3 and IPC-5 power supply. Standard 110VAC plug to Minifit Jr. 8-pin connector. 78.25". (Cable comes with supply.)
2	PC-SBR-72	Power cable, Sabre to Sabre, 72".
3	CPM-CABLE-PWR-MS120	ClearPath power cable. MiniFit Jr.4-pin to Sabre 2-pin, 120".
4	CPM-CABLE-M2P2P-120	2-pin Molex to 2-pin Molex multi-purpose cable, ~10 ft long.

Single POWER4-HUB System

DUAL POWER4-HUB SYSTEM

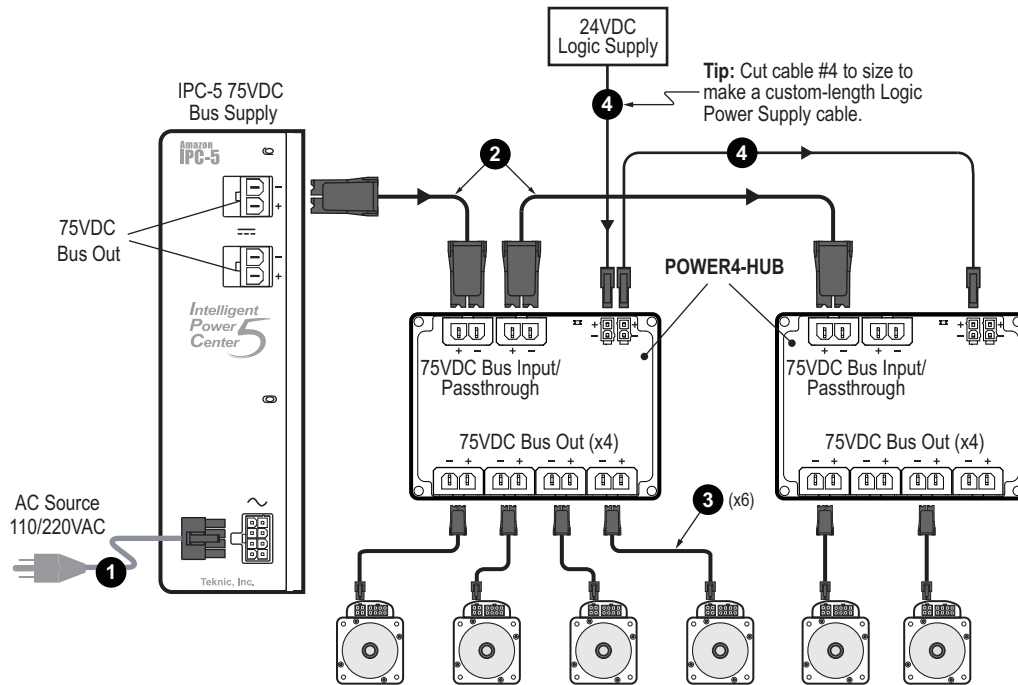

Ref.	Part Number	Description
1	IPC35-CABLE110	AC Line Cord for IPC-3 and IPC-5 power supply. Standard 110VAC plug to Minifit Jr. 8-pin connector. 78.25". (Cable comes with supply.)
2	PC-SBR-72	Power cable, Sabre to Sabre, 72".
3	CPM-CABLE-PWR-MS120	ClearPath power cable. MiniFit Jr.4-pin to Sabre 2-pin, 120".
4	CPM-CABLE-M2P2P-120	2-pin Molex to 2-pin Molex multi-purpose cable, ~10 ft long.

Two POWER4-HUBs powering 6 ClearPath-IP motors

LOGIC POWER SUPPLY (24VDC)

The POWER4-HUB requires a separate 24VDC supply. **Important: Do not use the main DC motor power supply for this purpose, even if it happens to be 24VDC.**

I/O HUB

INTRODUCTION

The **I/O HUB** serves as both the EtherNet/IP™ communication interface and the I/O and motor connection hub for ClearPath-IP systems. Each hub appears as a single device on the EtherNet/IP™ network and can support two or four ClearPath-IP motors, depending on the model.

Each I/O HUB has a built-in two-port Ethernet switch. This enables multiple hubs to be daisy-chained or connected directly to existing network drops and switches.

The I/O HUB directly interfaces with:

- EtherNet/IP™ Master/Scanner
- ClearPath-IP motors (2 or 4 depending on model)
- Input devices, such as sensors, switches, brakes, potentiometers, etc.
- Output devices, such as brakes, LED indicators, etc.
- A PC, via USB, for setup and configuration tasks

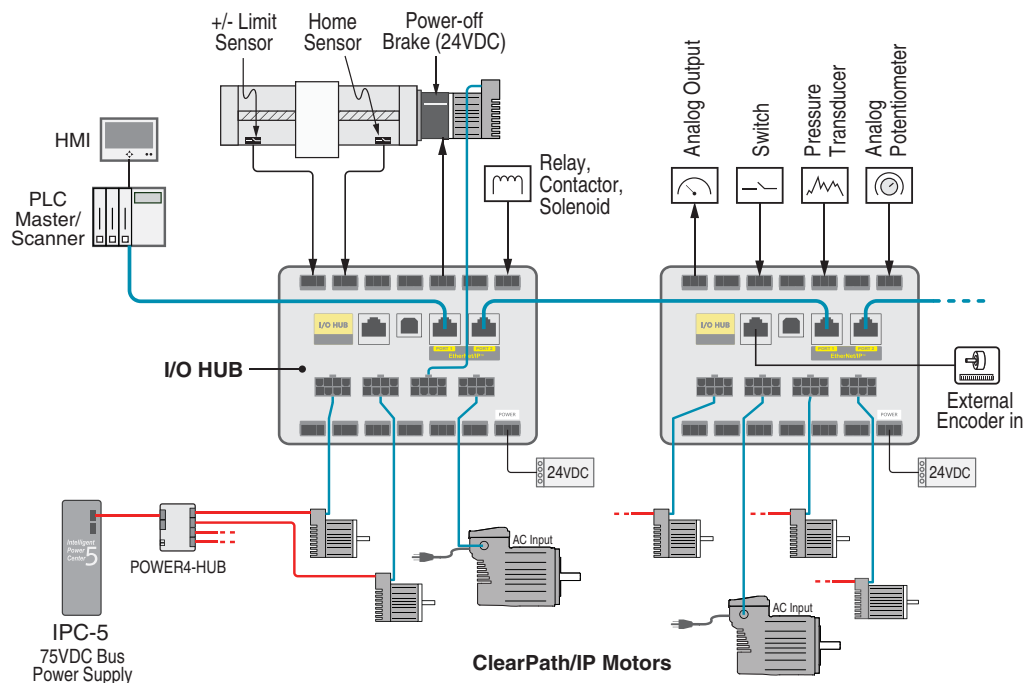

I/O HUBs in a ClearPath-IP system

PARTS OF AN I/O HUB

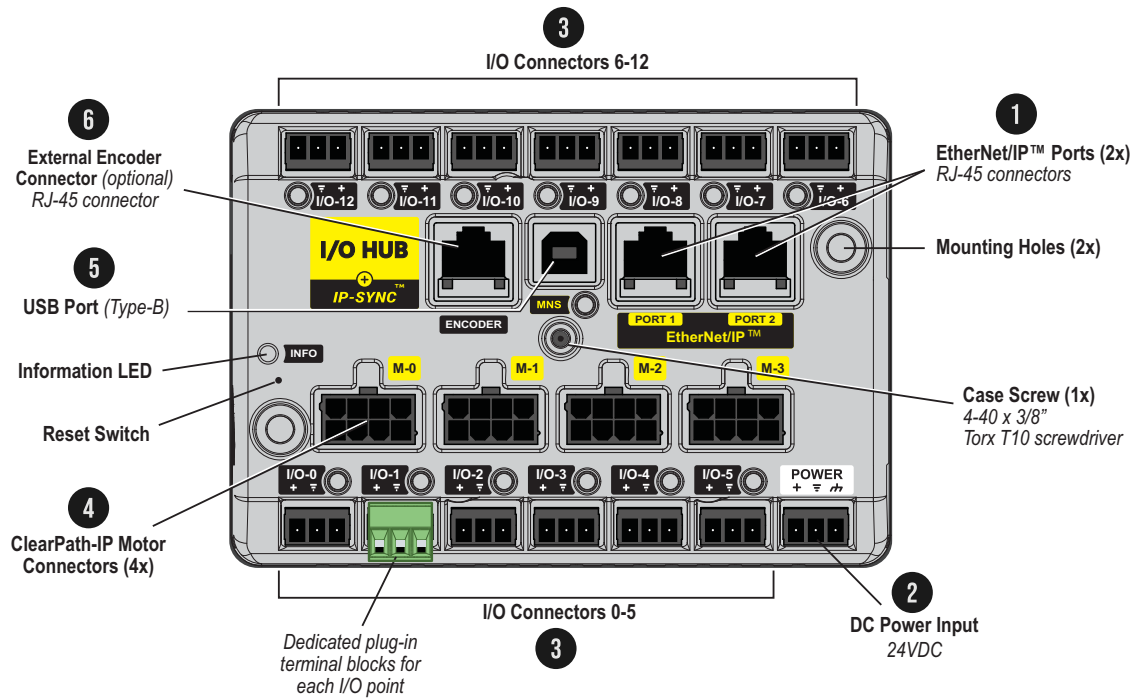

I/O HUB with callouts

MAIN CONNECTORS

1) EtherNet/IP™ Ports (2x) - Connect your EtherNet/IP™ network to either of these RJ-45 connectors, or make use of the built-in switch feature to daisy-chain I/O HUBs or to connect other network devices. Note: always use CAT-5e cable or better.

2) Power Input Connector - Connect 24VDC power to this 3-position connector. See Powering an I/O HUB later in this section. Note: I/O HUBs can be powered from lower voltages (down to 12VDC), but 24VDC is the most common supply voltage used for this product.

3) I/O Connectors - There are 13 3-position I/O connectors that can support simple switches, NPN and PNP sensors, analog I/O, spring-applied brakes, relays, GPIO, external encoder input and more³.

4) ClearPath-IP Motor Connectors - Connect your ClearPath-IP motors here. The required cable is a straight-through, 8-pin to 8-pin Molex MiniFit Jr. cable.

5) USB Port - Connect your PC running ClearView 3.0 to this USB-B connector for I/O HUB setup and configuration tasks. Use only high quality, data-rated USB cables.

6) External Encoder Connector - (*Applies to IO-HUB-4-E only*) Connect an optional third-party 5V differential encoder to this standard RJ-45 connector. Courtesy 5V power is provided at connector.

³ Check your I/O HUB model for supported features.

I/O HUB MODELS AND FEATURES

Teknic offers three I/O HUB models with different motor and I/O capabilities. See model descriptions and features by model for details.

Note: The last two characters in an I/O HUB model number indicate the number of motors the model supports, 2 or 4, and the type of I/O available, -E or -R.

I/O HUB MODEL NUMBERS

IO-HUB-2-R supports up to 2 CPM-IP motors, and R (*Motor I/O*) functionality.

IO-HUB-4-R supports up to 4 CPM-IP motors and R (*Motor I/O*) functionality.

IO-HUB-4-E supports all features. This includes R (*Motor I/O*) and E (*Enhanced I/O*) functionality.

TABLE OF I/O HUB FEATURES BY MODEL

Note: Model IO-HUB-4-E supports four motors and all I/O HUB features.

Table Key

ALL = Feature available on ALL I/O HUB models.

2R = Feature available on IO-HUB-2-R.

4R = Feature available on IO-HUB-4-R.

4E = Feature available on IO-HUB-4-E.

Connector Name	Digital Inputs		Digital Outputs		Analog Inputs	Analog Output	ClearPath-IP Motors	Encoder Input
	Motor I/O	GPIO	Motor I/O	GPIO PWM Capable				
I/O-0	ALL	4E	ALL	4E	4E			
I/O-1	ALL	4E	ALL	4E	4E			
I/O-2	ALL	4E	ALL	4E	4E			
I/O-3	ALL	4E	ALL	4E	4E			
I/O-4	ALL	4E	ALL	4E	4E			
I/O-5	ALL	4E	ALL	4E	4E			
I/O-6	ALL	4E	ALL	4E	4E			
I/O-7	ALL	4E	ALL	4E	4E			
I/O-8	ALL	4E	ALL	4E	4E			
I/O-9	ALL	4E	ALL	4E	4E			
I/O-10	ALL	4E	ALL	4E	4E			
I/O-11	ALL	4E	ALL	4E	4E			
I/O-12	ALL	4E			4E	4E		
M-0							ALL	
M-1							ALL	
M-2							4R, 4E	
M-3							4R, 4E	
ENCODER								4E

“MOTOR I/O” (ALL MODELS)

The **Motor I/O** type lets you assign I/O devices such as sensors, switches, or brakes to predefined motion-related functions.

Each Motor I/O function can be assigned to any available I/O point and then mapped to a specific motor connected to the I/O HUB. Motor and I/O configuration is done using either ClearView 3.0 or programmatically through the Master controller.

Motor I/O points may be assigned to any of these predefined functions:

- Positive Limit Input
- Negative Limit Input
- Home Switch Input
- Stop Switch Input
- Position Capture Input
- Brake Output

Note: Motor I/O is not general-purpose I/O (GPIO). The Master/Scanner cannot directly read or write to Motor I/O points. Only the Enhanced I/O HUB model supports GPIO functionality.

How to configure Motor I/O in ClearView 3.0

1. Connect the I/O HUB to your PC running ClearView 3.0 via the USB port.
2. Set the I/O HUB to **Full Access** mode.
3. Click on the desired motor connector from the UI graphic (**M-0**, **or M-1** for example).
4. Click **Configure** to open the Motor Configuration window.
5. Decide which Motor I/O function you want to configure (for example, **Positive Limit**).
6. Next to the [Positive Limit] function, select the desired I/O connector from the I/O Point dropdown list (**I/O-1** for example).
7. Select the device type from the **Configuration** dropdown list (e.g., Switch, NPN, PNP).
8. Select the "Trigger On" behavior. This defines the condition under which the I/O point is considered asserted.

"ENHANCED I/O" (-E)

The Enhanced I/O Model (IO-HUB-4-E):

- Supports all -R (Motor I/O) functions.
- Supports general-purpose I/O (GPIO) in any combination up to:
 - 13 digital inputs
 - 12 digital outputs (PWM capable)
 - 13 analog inputs
 - 1 analog output on I/O-12 only (4-20mA or 0-20mA)
- **External Encoder Input** - The I/O HUB features one dedicated RJ-45 encoder input port.

Note: Third-party encoders must support differential RS-422 quadrature signals to channels A and B; an optional index channel (I) is supported. The port provides 5VDC@300mA courtesy power.

Enhanced I/O points can be read and written by the Master controller. Configuration is performed through ClearView 3.0, or programmatically through the Master/Scanner.

How to configure Enhanced I/O in ClearView 3.0

1. Connect the I/O HUB to your PC running ClearView 3.0 via the USB port.
2. Set the I/O HUB to **Full Access** mode.
3. Click on the desired I/O connector from the UI graphic (**I/O-0**, or **I/O-1**, for example).
4. From the center drop-down list, select an I/O configuration (for example, Digital Input).
5. Select the appropriate Input or Output Wiring Option from the drop-down list (for example Switch, NPN, or PNP device).
6. Configure other options as presented in the setup dialog, if any.

POWERING AN I/O HUB

TOOLS AND PARTS REQUIRED:

- **Power supply (24VDC⁴).** The minimum required wattage depends on the total power draw of all connected devices. See the I/O HUB specifications for details.
- **Slotted screwdriver.** A 2 mm blade is recommended.
- **Wire cutter/stripper.**
- **Connectors:** Three-position Molex P/N 0395105003. These connectors are available at Teknic.com. Order PN [CC-3TERM-PLUG-10PC](#).

WIRING INSTRUCTIONS

1. Turn off power supply.
2. Strip positive and negative wires coming from the power supply. Strip length: 0.25" (6.5 mm).
3. Insert wires into terminal block as shown below.
4. Tighten terminal screws.
5. Visually inspect the connector for good wire capture. Verify that no wire insulation is captured in the closure, and that no loose wire strands are present.
6. Recommended: Before connecting the terminal block to the I/O HUB, test for correct voltage polarity between "+" and ground terminals.

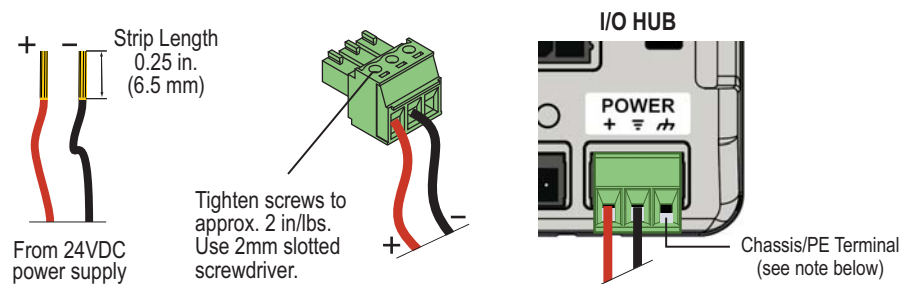

Chassis Connection: If direct mounting to a PE-bonded chassis is not possible, connect the chassis terminal to a nearby PE-bonded point on the machine. Use uncoated, conductive hardware, and ensure the connection is made to an uncoated, conductive part of the chassis close to the I/O HUB.

⁴ The recommended supply voltage for the I/O HUB is 24VDC. The hub can also operate with supply voltages as low as 12VDC; however, when using a lower voltage supply (e.g., 12VDC), use only I/O devices rated for that voltage.

TEKNIC 24VDC POWER SUPPLY

The [PWR-IO-24VDC](#) power supply (Mean Well PN LRS-150-24) is an inexpensive, 24VDC, 6.5A (156W) switching supply capable of powering most ClearPath-IP and I/O HUB applications.

[Product Datasheet](#)

[Installation Information](#)



Application Note: A higher-current power supply may seem excessive for an I/O HUB application, but it helps ensure that the processor remains powered under adverse conditions, such as overloads or shorts. It also provides overhead for future expansion if additional I/O devices are added. Lower-current supplies, in some cases, may experience shutdowns or brownouts when the I/O HUB is overloaded or shorted.

SETTING THE I/O HUB IP ADDRESS

1. Apply power to the I/O HUB.
2. Open ClearView 3.0.
3. Connect a USB cable from your computer to the USB port on the I/O HUB. The I/O HUB will show up in ClearView's Device List. Note: Use a high speed, data-rated USB cable.
4. Set the I/O HUB Access Level to "Full". Access Level settings are located at upper right of the ClearView 3.0 UI.
5. Plug your network cable into Port 1 or Port 2 of the I/O HUB.
6. Click the "Edit Network Settings..." button at bottom of UI; or, choose *Setup>Edit Network Settings...* from the main menu.
7. Follow the instructions in the Network Settings dialog window to configure for DHCP or Static IP settings.

I/O WIRING

This section contains hookup diagrams and wiring details for connecting common I/O devices to an I/O HUB.

Note: 24VDC is the recommended supply voltage for an I/O HUB; however, the device will operate properly at lower voltages; 12VDC is the practical minimum.

DAMAGE WARNING: Never apply an external voltage higher than your chosen V_{supply} to any I/O point on the I/O HUB. Doing so will damage the hub's circuitry.

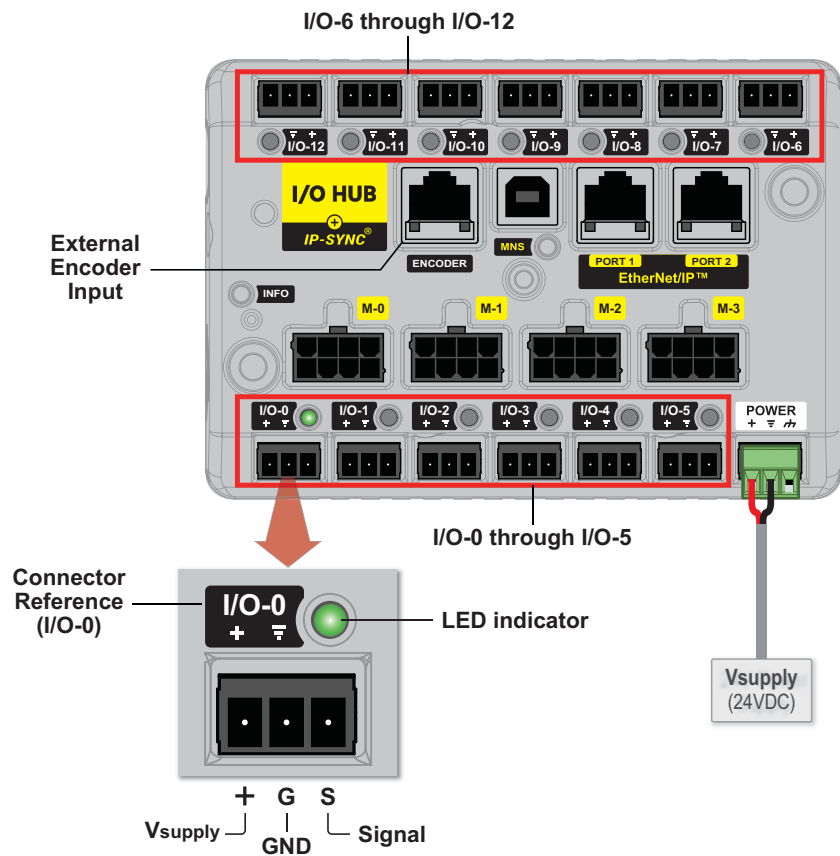

I/O HUB with enlarged view of I/O-0

DIGITAL INPUTS: SWITCHES, NPN LOGIC DEVICES

Supported I/O HUB models

- IO-HUB-2-R
- IO-HUB-4-R
- IO-HUB-4-E

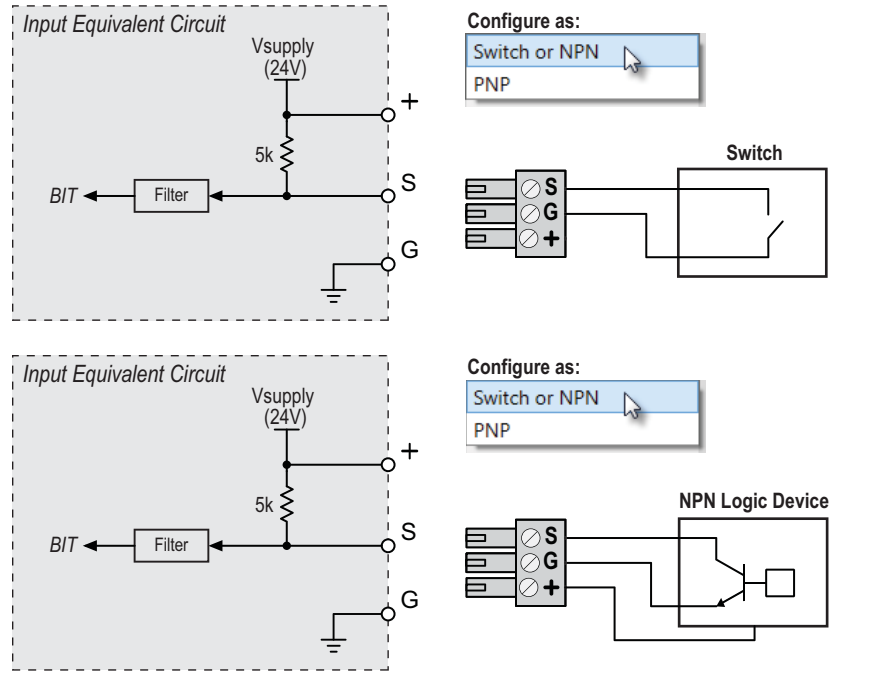

DIGITAL INPUTS: PNP LOGIC DEVICES

Supported I/O HUB models

- IO-HUB-2-R
- IO-HUB-4-R
- IO-HUB-4-E

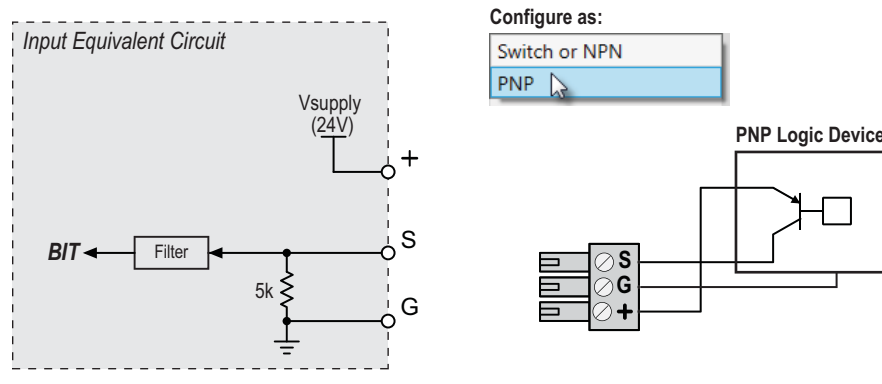

DIGITAL OUTPUTS: GPIO (PUSH-PULL, PWM)

Supported models:

- IO-HUB-4-E

Digital Output / PWM Output

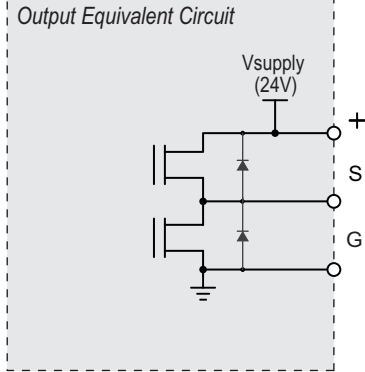

Solid State Relay (SSR)

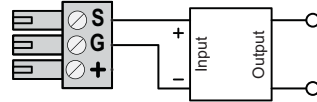

DC Fan / DC Motor

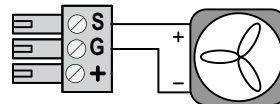

LED Indicator

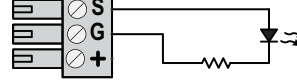

Coil-Driven Device

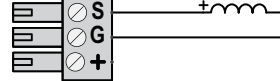

Note: a shunt diode is *not* required

Configure as GPIO:

Digital Output
 Output Wiring Options ?
 24V Push-Pull

or

PWM Output
 Output Wiring Options ?
 24V Push-Pull

Examples of coil-driven devices

- Relays
- Vacuum Valves
- Contactors
- Solenoid Actuators
- Brakes
- Pneumatic Valves

DIGITAL OUTPUTS: MOTOR I/O (BRAKE OUTPUT)

When configured as *Motor I/O*, this output serves as a pre-programmed brake output.

Supported models

- IO-HUB-2-R
- IO-HUB-4-R
- IO-HUB-4-E

Digital Output / Motor I/O Brake

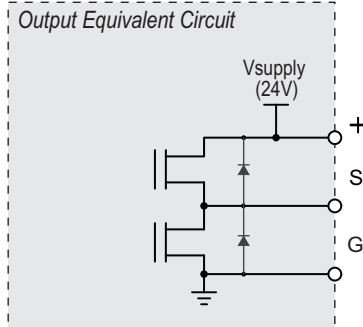

Configure as:

Brake Output I/O 0 24V Push-Pull

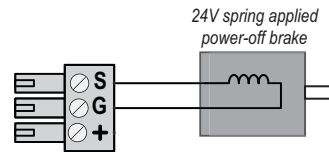

Note: a shunt diode is *not* required

DIGITAL OUTPUTS: OPEN-COLLECTOR (3.3V AND 5V INPUTS)

Supported I/O HUB models:

- IO-HUB-4-E

Digital Output Open-Collector mode allows you to connect I/O HUB outputs directly to lower voltage logic inputs, such as a 5V or 3.3V logic inputs.

Damage Warning: Use 3.3/5V Open Collector Output mode only. Push-Pull mode should not be used.

Application Notes

- Lower-voltage inputs may include internal protection circuitry to clamp the signal voltage to a safe level. If such protection is not present, the input can be damaged by direct connection to 24V. Check the manufacturer's documentation if you are unsure.
- Install a **zener diode** if the logic input cannot safely tolerate a 24V open-collector output (or if you aren't sure). Select a standard zener diode with zener voltage close to the input's nominal logic level. Use a 5.1V zener for 5V logic inputs; use a 3.3V zener for 3.3V inputs. See figure below for zener placement information.
- Even with a zener diode installed for voltage limiting, the I/O HUB output **must be configured for Open-Collector mode**.

Digital Output: Open Collector

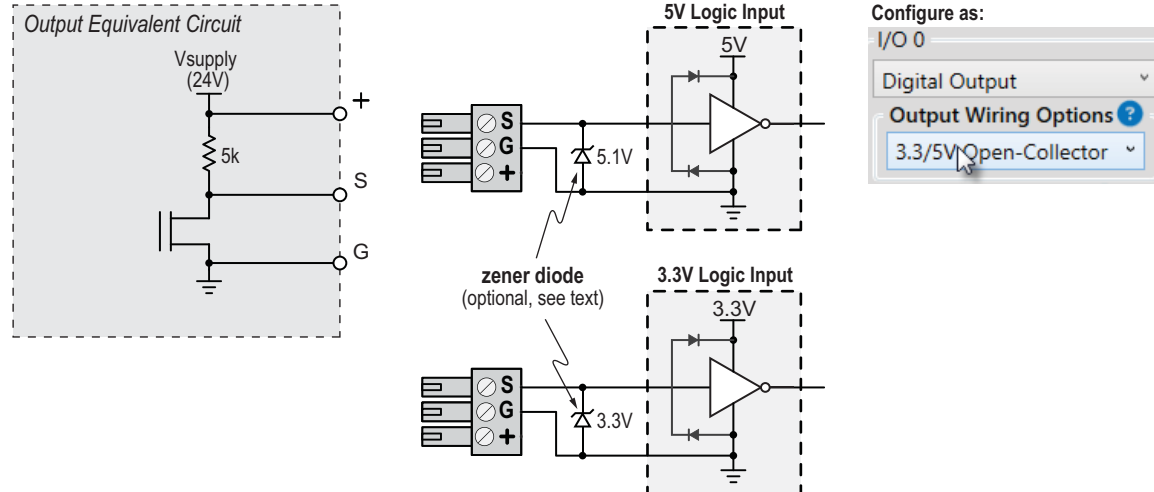

ANALOG INPUTS: POTENTIOMETER, TRANSDUCER

Supported I/O HUB models

- IO-HUB-4-E

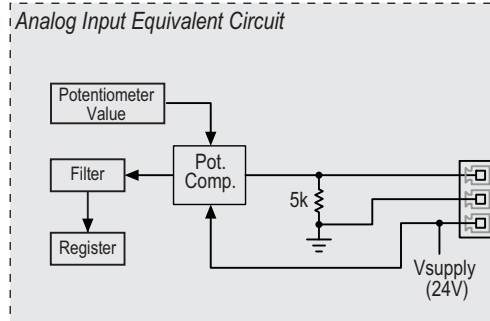

Configure as:

Analog Input

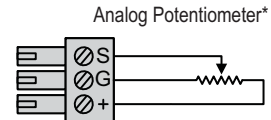

* Recommended potentiometers
1kΩ, 5kΩ, 10kΩ

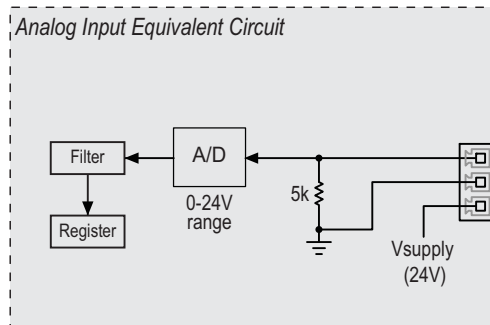

Configure as:

Analog Input

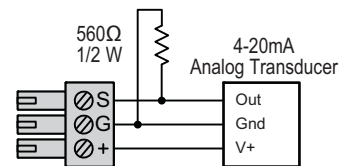
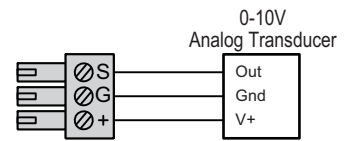

Note: Place shunt resistor close to terminal block.

ANALOG OUTPUTS: VARIOUS

Supported I/O HUB models

- IO-HUB-4-E (*applies to I/O-12 only*)

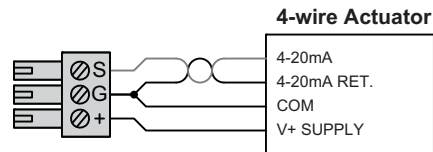
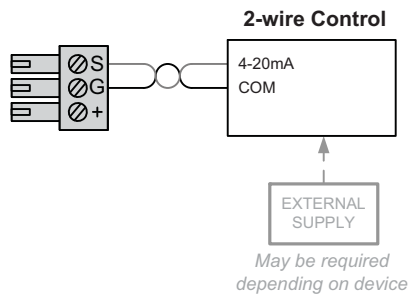
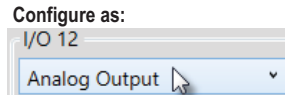
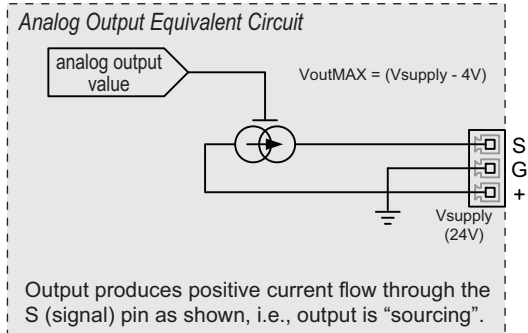

- Notes:
- Connect signal and supply return wires close to output terminal block
 - Use twisted pair as shown for best noise immunity

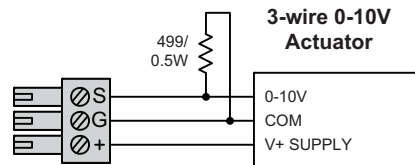
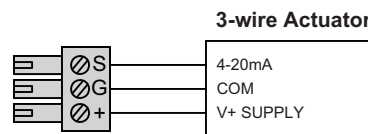

- Note:
- Place 499 Ohm shunt resistor close to actuator

ENCODER INPUT

Connect an external encoder to the I/O Hub for encoder-following and external position-reference functions. Refer to the [ClearPath-IP Software Reference Manual](#) for programming information.

Supported I/O HUB models:

- IO-HUB-4-E

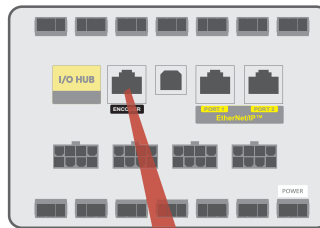

External Encoder Requirements

- Differential, quadrature A/B/I
- RS-422 signal levels
- 5VDC@300mA courtesy power at jack
- Max. 10 Mhz quadrature count rate

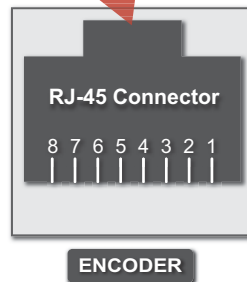

Pin#	Signal
1	ENC A
2	ENC A~
3	GND
4	ENC B
5	ENC B~
6	5V (out)
7	ENC I
8	ENC I~

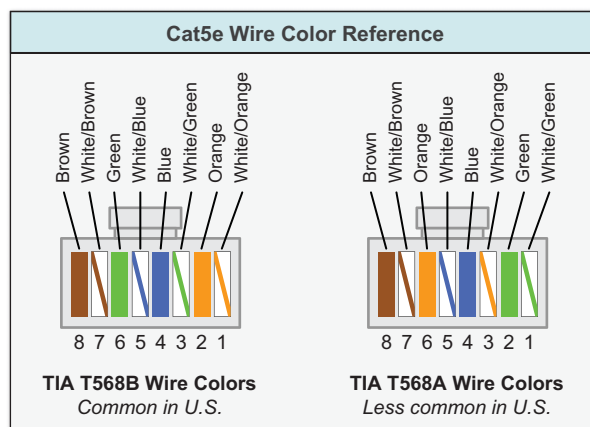

Notes:

- Use high quality CAT5e cable or better.
- External encoders are not sold or supplied by Teknic.
- 5VDC courtesy power and ground provided at pins 3 and 6. Maximum current is 300mA.

SOFTWARE (CLEARVIEW 3.0)

ClearView 3.0 is the configuration and diagnostic application for ClearPath-IP systems. ClearView 3.0 allows you to:

- View and interact with the ClearPath-IP motors and I/O HUBs on the network.
- Load motor configuration files and I/O HUB configuration files.
- Configure motor settings and I/O HUB network settings.
- Auto-Tune ClearPath-IP motors.
- Use the Move Generator and Jog Motion controls to test, refine, and troubleshoot motion and mechanical performance (without a controller present).
- Access the software oscilloscope to analyze motor variables in real time. Variables include Measured Torque, Position Error, Measured Velocity, Bus Voltage, and more.
- Assign functions to the I/O points on the I/O HUB.

MINIMUM SYSTEM REQUIREMENTS

Operating System:	Windows 10, 11
Processor:	1.5 GHz or faster. ARM-based processors not supported.
Memory:	1 GB RAM
HD Free Space:	1 GB
Monitor:	1280 x 1024 pixels or higher
Other:	Sound card with speakers (optional)

DOWNLOAD LINK

Download the ClearView 3.0 installer from
<https://www.teknic.com/downloads/>.

APPENDIX A: TROUBLESHOOTING

The ClearPath-IP motor and I/O Hub each include LED indicators that provide visual feedback on system operating status.

This section describes:

- The names and physical locations of each LED indicator.
- The meaning of each LED color and flash pattern.

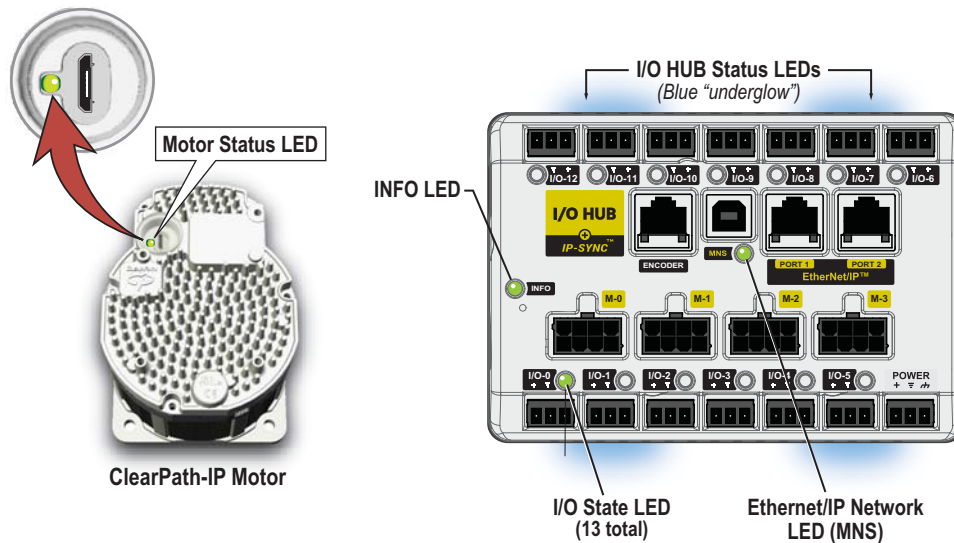

- **Motor Status LED:** Indicates whether the motor is enabled, disabled, or in a shutdown.
- **I/O HUB Status LED:** These LEDs, seen as a blue underglow around the base of the I/O HUB, indicate the ongoing operational state of the I/O HUB. During normal operation, the LEDs fade in and out at a regular interval. When an I/O HUB warning is triggered, the normal breathing pattern is replaced with a blink code corresponding to the specific warning.
- **Info LED:** Mirrors the behavior of the I/O HUB Status LED when an I/O HUB warning is present.
- **I/O State LEDs:** These LEDs (13 in all) show the logical state of each I/O point on the I/O HUB.
- **MNS LED (EtherNet/IP™ Network):** Displays the device's connection and communication status on the EtherNet/IP™ network.

LED CODES: CLEARPATH-IP MOTOR

The **Motor Status LED** at rear of motor, indicates the motor's current operational state (enabled, disabled, shutdown etc.). Refer to the table below for more information. For more detailed information on motor shutdowns, connect to the motor using ClearView 3.0.

LED Behavior	Motor State	Description
Green, rapid flicker	Enabled	Operation normal. CAUTION: Motor windings are energized. Motor can move at any time.
Green, solid	Disabled	Operation normal. Motor windings are de-energized.
Yellow, blink	Shutdown	Query drive through application code for exception information, or connect to motor via it's USB Diagnostic Port with secondary laptop running ClearView 3.0.
Red, blink	Fatal error	Motor hardware failure possible. Request RMA if condition persists.
Off	No, or low, DC bus power	Apply DC bus power to motor. Verify power supply meets system power requirements.

Note: The Motor LED will periodically blink off to indicate active communication with the network. This brief blink occurs alongside the standard LED behavior described above. See the examples below.

Example 1: A motor that is *disabled* will show a solid green LED, but the LED will blink off and on during periods of active communication.

Example 2: A motor that is *enabled* will exhibit a rapid green flickering LED, but the flicker pattern will be interrupted during periods of active network communication.

LED CODES: I/O HUB STATUS LED AND INFO LED

The **I/O HUB Status LED** is the blue "underglow" at the base of the I/O HUB. During normal operation this LED fades in and out in a slow breathing pattern. The **Info LED** (top left of the device) mirrors the behavior of the I/O HUB Status LED when (and only when) a warning is present.

I/O HUB Status codes are divided into three segments. Refer to the description and timing table below.

- **The Start-of-Code** segment is indicated by a 2.3 second strobing pulse, followed by a 1/2 second off period.
- **The Code Group** segment follows the Start-of-Code segment and indicates the general category of the warning (e.g., 'Device Error'). It is defined by the number of strobing pulses. Each strobing pulse is 1/2 second on, followed by 1/2 second off.
- **The Code Value** follows the Code Group and indicates the specific warning within the designated Code Group. One pulse is defined as 1/2 second solid on, followed by 1/2 second off.

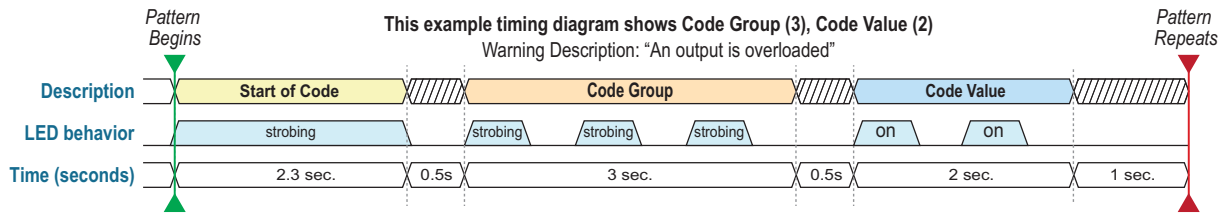

Note: If multiple I/O HUB warnings are present simultaneously, the codes will be displayed sequentially with a brief pause between codes.

Code Group	Code Value	Description
1 Strobe: HW Failure	1 Blink: Unit Requires Repair	Hardware problem. Return unit to Teknic.
2 Strobes: Device Error	1 Blink: IP Address Conflict	The I/O HUB's configured IP Address is the same as another device on the network. Make sure the I/O HUB has a unique IP Address configured in ClearView 3.0.
	2 Blinks: Config Load Required	Configuration file load failed. Try loading the file again, or reset the I/O HUB.
	3 Blinks: Encoder Noise	The I/O HUB detected noise on the external encoder input.
	4 Blinks: ADC Over-voltage	An analog input's voltage was too high. Check the I/O State LEDs to determine which analog input was overloaded.
3 Strobes: Power Error	1 Blink: 5V Supply Overloaded	The 5-volt supply for the Encoder Input has been overloaded.
	2 Blinks: Output Overloaded	An output on the I/O HUB has been overloaded. Check the I/O State LEDs to determine which output was overloaded.
	3 Blinks: Supply Voltage Too Low	The supply voltage dropped below 10 VDC. Check the I/O HUB's power supply.
	4 Blinks: Supply Voltage Too High	The supply voltage rose above 29 VDC. Check the I/O HUB's power supply.

LED CODES: MNS LED

The MNS (Module and Network Status) LED conveys information such as I/O HUB power status, IP Address status, and EtherNet/IP™ connection status.

LED State	Description
Steady Off	The I/O HUB is powered off, or is powered on but an IP Address has not been configured.
Flashing Green and Red	Startup sequence in progress.
Flashing Green	The I/O HUB's IP Address has been configured, but a communication link has not been established, and a connection timeout between the I/O HUB and PLC has not occurred.
Steady Green	The I/O HUB's IP Address has been configured, a connection has been established with at least one other Ethernet/IP™ device, and a connection timeout between the I/O HUB and PLC has not occurred.
Flashing Red	The I/O HUB's IP Address has been configured, and a timeout between the I/O HUB and PLC has occurred.

LED CODES: POWER4-HUB

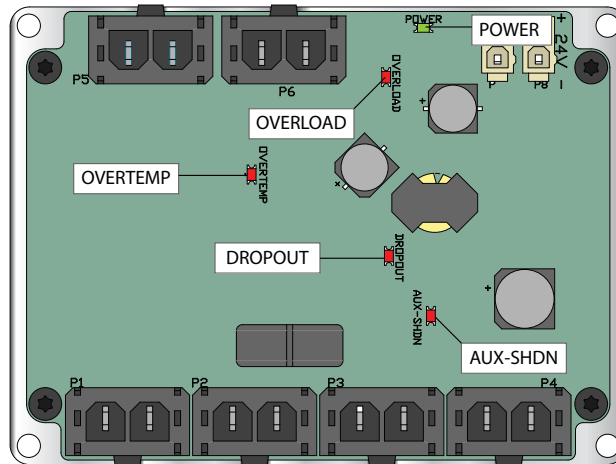

POWER4-HUB LEDs

LED Name	Color	LED On Indicates	LED Off Indicates
POWER <i>24V Power</i>	Green	Normal operation. Aux. 24V supply voltage detected.	Aux. 24V supply voltage not detected. Hub not functional.
OVERLOAD <i>Output Bus Overload</i>	Red	Short (or near short) circuit at bus output. POWER4-HUB electronically disconnects bus input from bus output in this case as a protective measure.	Normal operation.
OVERTEMP <i>Board Thermal Shutdown</i>	Red	Board temperature has exceeded 105°C. (Note: After an overtemp event, LED will turn off when board temp falls below 95°C.)	Normal operation. (Board temp is < 105°C.)
DROPOUT <i>75V Dropout LED</i>	Red	Bus supply has "dropped out", meaning the DC Bus has fallen below 18.2 VDC. Aux. power is active.	Normal operation.
AUX-SHDN <i>Aux. Power Overload</i>	Red	Motor bus has dropped out and aux. supply is in an overloaded state. (The motor load has exceeded 1000mA for >20mS.) This is a latching shutdown. You must cycle the aux. power supply to clear.	Normal Operation

APPENDIX B: MECHANICAL INDEX

DIMENSIONAL DRAWINGS

CLEARPATH-IP MOTORS

[23XX ClearPath Motor](#)

[34xx ClearPath Motor](#)

I/O HUB AND DIN RAIL MOUNT

[I/O HUB](#)

[DIN-MNT](#) (optional DIN rail mounting plate for I/O HUB)

POWER DISTRIBUTION BOARDS

[POWER4-HUB](#)

[POWER4-STRIP](#)

FAN MOUNTING

ClearPath-IP motors have an unthreaded mounting boss on the rear casting to accommodate standard DC computer fans (60mm for NEMA 34 motors, or 40mm for NEMA23 size motors). See the diagram below for mounting dimensions, hardware and fan sizes. Teknic does not sell accessory fans, but they are readily available through electronics suppliers such as DigiKey and Mouser.

Note: As a self-protective measure, ClearPath-IP motors will shut down when the rear enclosure reaches 80° C (176° F). After a thermal shutdown occurs, the motor must cool sufficiently before it will operate again.

Reminder: If you install a fan, you'll have to power it. Most computer fans require 12VDC or 24VDC.

ClearPath NEMA 34 Designed for 60mm fans

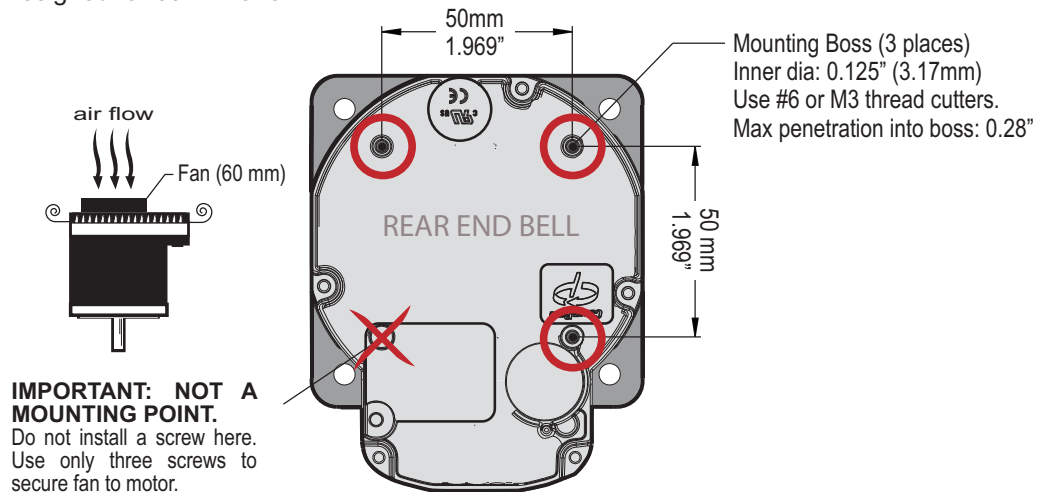

ClearPath NEMA 23 Designed for 40mm fans

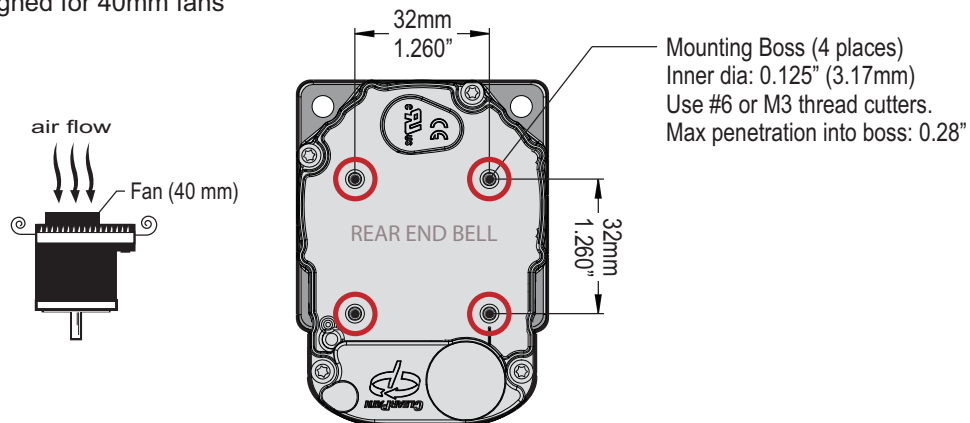

MOTOR MOUNTING, THERMAL CONSIDERATIONS

- Do not mount ClearPath-IP over a heat source such as a power supply, spindle drive, etc.
- Do not mount ClearPath-IP in an unventilated enclosure.
- Do allow for at least 1” of space around each ClearPath-IP.
- ClearPath-IP can be fitted with an external accessory fan if desired.
- ClearPath-IP will perform a protective shutdown when its internal temperature sensor threshold is exceeded.

Ease-of-use tip: Consider mounting the motor such that the USB port and status LED are visible and accessible when the motor is mounted to the machine. This will make it easier to view LED codes and plug in a USB cable to the diagnostic port.

CONNECTING CLEARPATH-IP TO A MECHANICAL SYSTEM

ClearPath-IP motor must be connected to a mechanical system to do any useful work, but it's not always clear just how to connect the motor to the rest of the machine.

Problems arise when a connecting element (such as a coupling) slips, exhibits excessive backlash, or can not accommodate typical shaft-to-shaft misalignments. Ultimately, the choice of shaft interface or coupling depends on the application, whether a precision positioning stage or a low speed conveyor.

The shaft interface (coupling, pulley, pinion, etc.) must be securely clamped to the shaft with minimum backlash (ideally none). This primary mechanical interface is critical in achieving and maintaining the best possible performance from a servo motion system.

MOTOR CONNECTION: GENERAL TIPS AND GUIDELINES

- **Align with care.** When connecting two shafts—such as a motor shaft to a screw shaft—the rotating centers must be carefully aligned in both the angular and offset sense (including offsets/adjustments for thermal growth) to achieve the best possible motion quality and longest motor/bearing life.

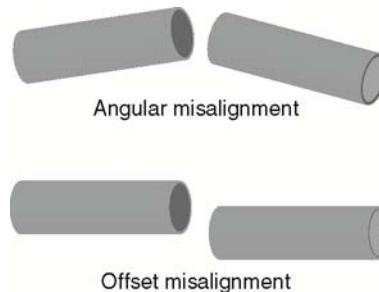

Some couplings are more forgiving of misalignment than others, but in general, misalignment will cause undesired vibration/noise, shortened bearing life, and even broken motor shafts.

- **Use lightweight components.** Aluminum couplings, pinions, and pulleys add significantly less inertia to the motion system than steel parts of the same size. In most applications, lower inertia is preferable because it allows the motor (and attached mechanics) to accelerate harder and move and settle faster.
- **Avoid using set screws.** Coupling devices with set screws are prone to failure and often become the weak link when joining a motor to a load. Set screws deform the metal around the screw's point of contact, often resulting in a raised burr on the shaft that can make it hard to remove and replace the coupling element. Set screws also tend to slip and score the shaft.
- **Tip:** Couplings, pulleys and pinions with circumferential clamping mechanisms tend not to damage motor shaft, hold better, and are easier to replace than those that use set screws.

- **Clamp close to the motor.** For maximum performance, secure pulleys and pinions as close to the motor face as practical. This effectively reduces the lever arm (and associated bearing load) for applications with a side load.
- **Don't over tighten belts.** Always read the belt manufacturer's guidelines for proper belt tension, but never exceed the ClearPath-IP specification for maximum side load. Overly tight belts put undue stress on the motor shaft and bearing systems that can result in premature bearing and shaft failure.
- **Avoid using shaft keys when possible.** Although ClearPath-IP includes a keyway feature on the shaft, Teknic does not generally recommend the use of keys. Keys tend to cause run-out and backlash errors, particularly in reciprocating, precision positioning motion applications.
- **Note:** Keys *should be* considered for use in applications where coupling slip could result in a dangerous or hazardous condition. Also, key use may be appropriate for unidirectional applications (where the motor always spins in the same direction) as these applications are less prone to key-related lash problems.
- **Avoid direct loads.** In general, ClearPath-IP motors are not designed for connection to direct loads (e.g. direct connection to a grinding wheel). However, direct connection may make sense if the load is of low-mass and balanced, as with small mirrors for laser applications.

NOTES ON COUPLING SELECTION.

General Guidelines for Coupling Selection

Teknic has a few guiding principles when it comes to coupling selection for servo applications. Keep in mind that these are rules of thumb and may not apply to every application. In general:

- **Don't** undersize the coupling. Understand how much torque your application requires and stay within the coupling manufacturers specifications. Always leave reasonable engineering margin.
- **Don't** use set screw type couplings. They damage the motor shaft and tend to be less reliable over time than clamp style couplings.
- **Do** use clamp style couplings. These clamp around the circumference of the shaft at one or two points without deforming the shaft surface.
- **Don't** use rigid couplings—they are notoriously intolerant of misalignments.
- **Don't** use beam style (helical) couplings if vibration damping or torsional stiffness is critical to your application. Beam couplings tend to resonate/whine at higher speeds.
- **Don't** use any coupling that requires you to drill into, deform, or “pin” the motor shaft.

Coupling Recommendation

Teknic often recommends **zero-backlash curved jaw couplings** (commonly referred to as “spider couplings”) as a good choice for many servo applications. These couplings are moderately priced and widely available from well established manufacturers such as Ruland.



Curved Jaw (Spider) Coupling



Bellows Coupling

Couplings for servo applications

Note: Curved jaw couplings (also known as spider couplings) are a good choice for many applications, but cannot tolerate a great deal of misalignment or axial motion. Also, never exceed the manufacturer's rating for “maximum torque with zero backlash” when using jaw couplings.

Bellows couplings are also excellent for high precision positioning applications. Bellows couplings allow for more misalignment than jaw couplings but are generally more expensive.

Both curved jaw and bellows coupling offer excellent positioning accuracy, high speed performance, and vibration damping when installed and operated within the manufacturer's specifications and guidelines.

Information on the Web

For technical articles on coupling types and coupling selection, see links below.

<https://teknich.com/securing-mechanics-motor-shafts/>

<https://www.ruland.com/technical-resources/technical-articles>

<https://www.ruland.com/technical-resources/technical-articles/5-reasons-to-consider-using-jaw-couplings>

INSTALLING PULLEYS AND PINIONS

PULLEY AND PINION MOUNTING

- Always follow the manufacturers mounting guidelines.
- Mount pulleys and pinions as close to the motor face as possible while still following the manufacturer's installation guidelines.
- Never drill through, "pin", or deform the motor shaft when mounting a pulley or pinion.

Application Tip: To prevent loosening/slip, some users bond their pulleys and pinions to the motor shaft with a high strength adhesive such as Loctite #638. While this is very effective in preventing pulley slip, it can be difficult to undo once the adhesive has cured.

ABOUT END-OF-TRAVEL STOPS.

End-of-travel stops are typically installed to prevent the moving element of a linear axis from flying off the machine in the event of a use or control error. There are a few common types of end stop to consider, but the final choice depends on the application objectives and requirements.

HARD BLOCKS

This is usually a solid block of steel, aluminum, or hard plastic secured at one or both ends of travel and positioned in such a way as to make even, repeatable contact with a hard surface on the moving element. Hard blocks are very effective at arresting motion, but can result in mechanical damage when struck at high speeds.

In several modes, ClearPath-IP must home to a hard stop to establish a home reference position before functional positioning can begin.

ELASTOMERIC (RUBBER) STOPS

High durometer rubber stops (hard rubber) can also be used with applications that use HardStop Homing. This type of end stop offers a higher level of shock absorption and axis protection than hard blocks. Spongy, low durometer rubber stops are not recommended in most cases. They offer little benefit over a hard end stop during an axis crash.

PNEUMATIC (DASHPOTS)

Pneumatic hard stops (dashpots) offer excellent shock absorption performance but are considerably more expensive than hard blocks. Examples of specialized dashpots include the hydraulic cylinder in an automobile shock absorber as well as many automatic door closers.

END STOPS AND HARD STOP HOMING

End stops from medium durometer rubber to steel can be used successfully with Hard Stop Homing. When selecting end stops for a Hard Stop Homing application consider the following:

- Axes with low friction that are easily back driven can tolerate “softer” rubber end stops and still achieve good homing performance.
- Higher friction applications and those that cannot be back driven will generally require harder end stop material to achieve best Hard Stop Homing performance.
- Be prepared to test and experiment with different end block materials to ensure proper homing operation with your mechanical system.

APPENDIX C: MATING CONNECTORS AND CABLES

MATING CONNECTORS

This section contains a list of mating connectors, terminals, and hand tools for the ClearPath-IP components.

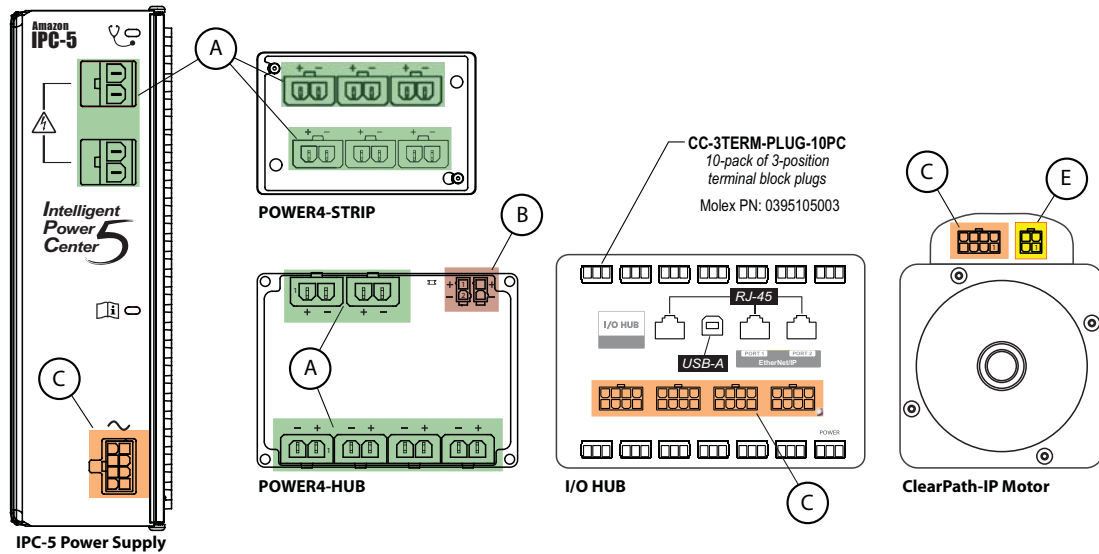

All parts listed below are made by Molex Inc. Go to www.molex.com for complete specifications and application information.

Ref.	Description	Mating Connector PN	Terminal PN	Terminal Desc.	Crimp Tool	Extraction Tool	Wire Gauge ²
A	Molex Sabre, Receptacle, 2 circuits	44441-1002 (black, UL 94V-2) 44441-2002 (black, UL 94V-0)	43375-0001	Female crimp terminal, tin plate, 14-16 AWG	63811-7200 (14-16 AWG)	63813-2700	16 AWG
B	Molex MiniFit-Jr, Receptacle, 2 circuits	39-01-2020 (natural, UL 94V-2) 39-01-3025 (black, UL 94V-2) 39-01-3028 (natural, UL 94V-0) 39-03-9022 (black, UL 94V-0)	39-00-0059 (reel) 39-00-0060 (loose)	Female crimp terminal, tin plate, 18-24 AWG	63819-0900 (16-24AWG)	11-03-0044	20 AWG
C	Molex MiniFit-Jr, Receptacle, 8 circuits	39-01-2080 (natural, UL 94V-2) 39-01-3085 (black, UL 94V-2) 39-01-2085 (natural, UL 94V-0) 39-03-9082 (black, UL 94V-0)	39-00-0046 (reel) 39-00-0047 (loose)	Female crimp terminal, tin plate, 22-28 AWG	63819-1000 (22-28 AWG)	11-03-0044	22 AWG
D ¹	Molex MiniFit-Jr, Receptacle, 4 circuits	39-01-2040 (natural, UL 94V-2) 39-01-3045 (black, UL 94V-2) 39-01-2045 (natural, UL 94V-0) 39-03-9042 (black, UL 94V-0)	39-00-0046 (reel) 39-00-0047 (loose)	Female crimp terminal, tin plate, 22-28 AWG	63819-1000 (22-28 AWG)	11-03-0044	22-24 AWG
E ¹	Molex MiniFit-Jr, Receptacle, 4 circuits ¹	39-01-2040 (natural, UL 94V-2) 39-01-3045 (black, UL 94V-2) 39-01-2045 (natural, UL 94V-0) 39-03-9042 (black, UL 94V-0)	39-00-0077 (reel) 39-00-0078 (loose)	Female crimp terminal, tin plate, 16 AWG	63819-0900 (16-24 AWG)	11-03-0044	16 AWG

¹Important Caution for D and E: While the same connector housing is specified for both D and E; the wire gauge and terminals specified are different!

²AWG values listed are the actual wire gauges used in Teknic-manufactured cables.

CABLE DRAWINGS

CONTROL CABLE: CPM-CABLE-CTRL-MU120

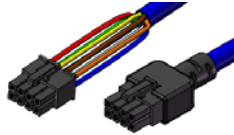

Cable description: ClearPath control cable, ~122 inches end-to-end. Overmolded Molex MiniFit Jr. 8-position connector to standard MiniFit Jr. 8-position connector (no overmolding on one end for easy access to wires). [Link](#)

CONTROL CABLE: CPM-CABLE-CTRL-MM660

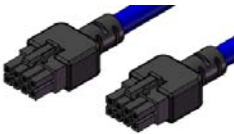

ClearPath control cable (double-ended), ~662" end-to-end. Overmolded Molex MiniFit Jr. 8-position connector to same. Use "as is" or cut in half to make two cables with flying leads. [Link](#)

POWER CABLE: CPM-CABLE-PWR-MM660

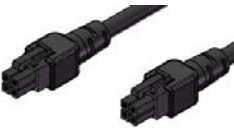

ClearPath power cable (double-ended). MiniFit Jr. 4-position connector to same; ~662" end-to-end. Designed to be cut in half (or as needed) to make up to two custom-length power cables with flying leads. [Link](#)

POWER CABLE: CPM-CABLE-PWR-MS120

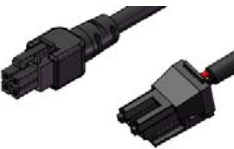

ClearPath power cable, ~122 inches end-to-end. This cable connects the DC output of a Teknic IPC-3 or IPC-5 power supply to the ClearPath power input connector. It features a Sabre 2-position connector to Molex MiniFit Jr. 4-position connector. [Link](#)

POWER CABLE: PC-SBR-72



Cable used to supply 75 volt bus power from an IPC-5 or IPC-3 to a ClearPath power distribution board (POWER4-HUB, POWER4-HUB-S, POWER4-STRIP, and POWER4-STRIP-S) or to daisy-chain multiple power distribution boards. Length: 6 ft. [Link](#)

NETWORK CABLE: CABLE-CAT5-120



Cat5e cable, ~120" end-to-end. Flexible, snag-free, cable boot protects the plug while making it easy to depress the locking clip. 24AWG stranded, pure bare copper conductors. 50µm gold-plated contacts. [Link](#)

APPENDIX D: SPECIFICATIONS

CLEARPATH-IP MOTOR: COMMON SPECIFICATIONS

Electrical Power Requirements:

Supply Voltage, Typical:	24VDC to 75VDC
Supply Voltage, Absolute Min:	21.5VDC (as measured at input terminals)
Supply Voltage, Absolute Max:	90VDC (as measured at input terminals)
Continuous Bus Current, Typical:	1A to 4A (application dependent)
Continuous Bus Current, Maximum:	10A
Idle Power usage from Bus	4W (enabled, using no torque), 3W (disabled)

Electrical I/O:

Logic Input Voltage Range:	4.0VDC to 28VDC
Input Current @ 5V:	7.5mA (min.)
Input Current @ 28V:	12.0mA (min.)

Encoder

Commandable Positioning Resolution	12,800 encoder counts/revolution
------------------------------------	----------------------------------

Motor Bearing, NEMA34:

Maximum Radial Load, NEMA34:	220N (50-lbs), applied 25mm (1.0in) from front bearing
Maximum Thrust Load, NEMA34:	44N (10-lbs)
Bearing Life, NEMA34:	2.4 x10 ⁹ to 5.3 x10 ⁹ revs (typ., load dependent.)

Motor Bearing, NEMA23:

Maximum Radial Load, NEMA23:	110N (25 lbs), applied 25mm (1.0in) from front bearing
Maximum Thrust Load, NEMA23:	22N (5 lbs)
Bearing Life, NEMA23:	3.2 x10 ⁹ to 5.0 x10 ⁹ revs (typ., load dependent.)

Environmental:

Shock (peak, maximum):	10G (applied no more than twice)
Vibration (RMS, 2 Hz-200 Hz):	1.0G or 0.5mm, whichever is less
Maximum External Shaft Deceleration:	250,000 rad/s ²
Ambient Temperature ¹ :	-40°C to +70°C
Maximum Body Temp.:	100°C
Maximum Rear Cover Temp.:	70°C
Humidity:	0% to 95%, Non-Condensing
Recommended Optional Fan, NEMA23:	40mm square, 45.25 mm bolt center, >7CFM
Recommended Optional Fan, NEMA34:	60mm square, 70.71 mm bolt center, >14CFM

Environmental Sealing:

Front Face, with shaft seal option:	IP65
Front Face, without shaft seal option:	IP53
Body/rear, w/ dielectric grease in connectors	IP55
Body/rear, no sealing provisions	IP53

Compliance:

Regulatory Certifications:	UL recognized, CE, RoHS
Electrical Safety:	UL508C, EN 61010-1
EMI:	EN 61326-1

Country of Origin:

USA

Warranty:

3 years

[1] The RMS torque limit on certain motors is derated for operation in ambient temperatures above +40°C. Contact Teknic for derating assistance.

I/O HUB SPECIFICATIONS

Mechanical

Dimensions	5.0" x 3.5" x 1.0" (127mm x 88.9mm x 25.4mm)
Weight (with cover)	6.66 oz (189 g)
Material	3mm thick polycarbonate cover, aluminum baseplate

Electrical

Voltage Input	10-28VDC (24VDC nominal)
Output Current Capability	I/O 0,1,2,3,4,5,6,7,8,9,10,11 - 750mA RMS (1000mA peak) each Group total for each 0/1/2/3, 4/5/6/7, 8/9/10/11 - 1.5A RMS (2A peak) Total continuous for all outputs - 4A RMS (7A peak for 10mS Max)
Power Consumption (I/O HUB only)	300mA @ 24VDC
Protection features	Overcurrent protection on all outputs Inductive clamping on all outputs Board master overvoltage and overcurrent protection ESD protection features on all I/O circuits
Capacitive load (max.)	Capacitance on I/O power pins collectively may not exceed 250uF.

Motion Axes by Model

IO-HUB-2-R	2 motion axes available per I/O HUB; with Regular (R) axis I/O only
IO-HUB-4-R	4 motion axes available per I/O HUB; with Regular (R) axis I/O only
IO-HUB-4-E	4 motion axes available per I/O HUB; with Enhanced (E) general purpose I/O (GPIO) and axis I/O

I/O Points by Model

Total I/O Points (all models)	13 built-in I/O points. I/O points each have an individual LED indicator.
IO-HUB-2-R	Software configurable I/O can serve as motion axis Home Switch Input, +/- Limit Switch Inputs, Stop Sensor Input, Position Capture Input, or Brake Output. I/O is not general purpose (i.e., the master/scanner cannot directly read or write this I/O). Analog I/O is not supported.
IO-HUB-4-R	Software configurable I/O can serve as motion axis Home Switch Input, +/- Limit Switch Inputs, Stop Sensor Input, Position Capture Input, or Brake Output. I/O is not general purpose (i.e., the master/scanner cannot directly read or write this I/O). Analog I/O is not supported.
IO-HUB-4-E	Supports all motion axis functions of the IO-HUB-2-R and IO-HUB-4-R (Home Switch Input, +/- Limit Switch Inputs, Stop Sensor Input, Position Capture Input, and Brake Output). In addition, this model supports software configurable GPIO in any combination of up to 13 digital inputs, 12 digital outputs (PWM capable), 13 analog inputs, and 1 analog output (4-20mA or 0-20mA). The master/scanner can directly read/write the GPIO.

External Encoder Input by Model

IO-HUB-2-R	No external encoder support
IO-HUB-4-R	No external encoder support
IO-HUB-4-E	1 RJ-45 port configured for optional external encoder input. Encoder requirements: 5V differential, quadrature A/B/I supported, index not required. RS-422 levels, Max. count rate 10Mhz 5V @ 300mA courtesy power available on this port.

Communications

Ethernet	EtherNet/IP™ in/out switching capability. Accessed via 2 standard RJ-45 ports. 10Base-T/100Base-TX Ethernet. Use CAT5e cable or better.
USB	USB 2.0, for configuration only

Environmental

IP rating	IP20
Operating Temperature/Humidity	-20°C to 50°C / 0-90% non-condensing
Storage Temperature	-40°C to 85°C

Compliance

CE (pending), RoHS

POWER4-HUB SPECIFICATIONS

24V power input (aux. power supply)

Specified voltage range:	20VDC to 30VDC
Absolute maximum input voltage:	40VDC
Current draw:	400mA Max.
Connectors:	2-pin Molex MiniFit Jr. (P7, P8)

A labeled green LED on the board will light when 24V power is connected.

75V power input (motor bus power)

Specified voltage range:	20VDC to 90VDC
Maximum input voltage:	100VDC
Continuous current draw:	20A
10-second current draw:	60A
Connectors:	2-pin Molex Sabre (P5, P6)

Power outputs to ClearPath motors

Max motors:	4
Connectors:	2-pin Molex Sabre (P1, P2, P3, P4)

Short-circuit protection

Actively protects connected power supplies from short-circuit/overload damage.
 No reset or fuse replacement is necessary after a short-circuit or overload incident.
 A labeled red LED on the board will light when short-circuit protection is activated.

Operating Temperature

40C Max.

Under voltage shutdown protection

Upon loss of motor bus power, the POWER4-HUB will automatically switch over to low-voltage aux. power to keep ClearPath communications and position tracking online.
 A labeled red LED on the board will light in a motor bus under voltage condition.

Auxiliary overload protection

Aux. overload threshold	1.0A
-------------------------	------

If an aux. overload event occurs while aux. power is active, the aux power supply will shut down until the 24V supply is power cycled.
 A labeled red LED on the board will light (and remain lit) when an aux. overload condition occurs.

Dimensions:

L x W x H (w/o plate)	3.92" x 3.09" x 0.95"
-----------------------	-----------------------

Country of Origin:

USA

Warranty:

1 year

APPENDIX E: GROUNDING AND SHIELDING

PROTECTIVE EARTH (PE) CONNECTION

Compliance Note: ClearPath-IP must be properly connected to the machine's Protective Earth terminal to meet EMC emissions specification EN-61000-6-4, and EMC immunity specification EN-61000-6-2, as well as EMC electrical safety specification EN-61010 (for CE/UL compliance).

Connect ClearPath-IP to your machine's Protective Earth terminal (PE) using one of the following methods.

- **If the motor mounting plate is bonded to machine PE (typical)**, most of the work is already done. Simply secure ClearPath-IP to the mounting plate with conductive fasteners (don't use anodized or coated hardware). Ensure direct, bare metal-to-metal contact between the ClearPath-IP motor face and mounting surface.
- **If the motor mounting plate is *not* bonded to machine PE** it's still easy to make a good PE connection. Just install a grounding wire from ClearPath-IP's Auxiliary PE Connection Point (located on the motor's rear casting) to a point on the machine that is bonded to machine PE. **Use #6-32, thread forming screw, 5/16" length** (McMaster-Carr PN 93878A145). Use grounding wire with same AWG number (or heavier) as the ClearPath DC power input wiring.

Note: In scenarios where ClearPath-IP *is not* connected to a PE (Protective Earth) return path—such as during bench testing or maintenance—temporary grounding measures may be necessary to comply with safety requirements.

GROUNDING AND SHIELDING

- Always maintain separation between isolated control ground and power ground.
- Shielded cable is not required for ClearPath-IP control cables.
- If you choose to use shielded control cable, connect the cable's isolated ground at one point at the controller only. Do not hook isolated control ground to the machine frame or chassis at any other location.
- Do not ground ClearPath-IP I/O circuits to the machine frame or chassis.

Note: All ClearPath-IP I/O signals are electrically isolated from ClearPath-IP's DC power input and motor output circuits, as well as from the motor case. This design feature helps to ensure that control signals aren't compromised by induced currents from the motor, power supply, or internal PWM.

POWER RETURNS

- Never use the machine frame or chassis as a power return. Use discrete cable or wires for all power wiring.
- Use only recommended wire gauge (16-18AWG typical) for all ClearPath-IP power wiring. When in doubt, use heavier wire.

APPENDIX G: MOTOR PART NUMBER KEY

Visit teknich.com and enter your motor part number into the search bar for complete information including specifications, torque-speed curves, and links to drawings and documentation.

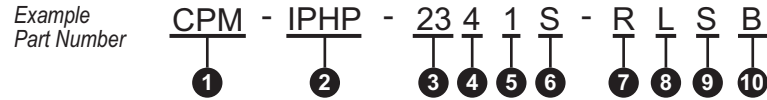

1	Product ID	CPM	ClearPath Motor
2	Family/Model	IPVC	Ethernet/IP™ Controlled / Velocity Control
		IPSK	Ethernet/IP™ Controlled / Stepper Killer
		IPHP	Ethernet/IP™ Controlled / High Power
3	Motor Frame Size	23	NEMA 23
		34	NEMA 34
4	Approx. Body Length	1	82mm
		2	100mm
		3	120mm
		4	140mm
5	Winding/Magnetic Structure	0	Each option indicates a different winding design. See your motor's torque-speed curve at teknich.com for more information.
		1	
		2	
		5	
6	Winding Type	S	Series-Wye (IP53)
		P	Parallel-Wye (IP53)
		D	Parallel-Delta (IP53)
		H	Series-Wye (IP67/IP66k)
		F	Parallel-Wye (IP67/IP66k)
		J	Parallel-Delta (IP67/IP66k)
7	Encoder Resolution	R	Positioning Resolution = 12800 counts per revolution
8	Shaft Diameter	L	Standard (1/2" for NEMA 34 models and 3/8" for NEMA 23)
		Q	1/4" shaft diameter (available on NEMA 23 models with 1 or 2 magnet stacks)
9	Shaft Seal	N	Standard dust sealing
		S	Extra Viton™ seal. This option is not available for 1/4" shaft models.
10	Feature Set	B	Basic firmware

APPENDIX H: MISCELLANEOUS TOPICS

POWER SUPPLY NOTES

TEKNIC IPC-3 AND IPC-5 POWER SUPPLY OVERVIEW

Teknic designed the IPC-3 and IPC-5 power supplies specifically for servo systems like the ClearPath-IP. These supplies deliver a tightly regulated 75VDC and feature large capacitor banks to prevent debilitating droop during peak current demand. The IPC supplies also feature advanced regenerated energy management and many built-in safety and protective features.



Teknic IPC-3



Teknic IPC-5

Teknic 75VDC IPC family power supplies

TEKNIC MODEL IPC-3

The IPC-3 power supply can typically power one to four ClearPath-IP motors. The actual number depends on the application—fewer when the motors are generating high torque continuously at high speeds, and more when the motors are intermittently using bursts of power like in many point-to-point positioning systems. Please visit Teknic's website (www.Teknic.com) for more information, features, and specifications.

TEKNIC MODEL IPC-5

The IPC-5—fully enclosed power supply—can typically power two to six ClearPath-IP motors. The actual number depends on the application—fewer when the motors are generating high torque continuously at high speeds, and more when the motors are intermittently using bursts of power like in many point-to-point positioning systems. Please visit Teknic's website (www.Teknic.com) for more information, features, and specifications.

DC BUS POWER SUPPLY SWITCHING AND FUSING

POWER SUPPLY ON/OFF SWITCH

If you need to install a power switch, install an appropriately rated device on the AC input side of the supply (see figure below). Do not install a

switch on the DC output side. Switching the DC output side—especially with inexpensive relays—will cause performance degradation over time due to pitting, corrosion and potential contact welding.

DC OUTPUT FUSE

If you require an external fuse on your power supply’s DC output (to meet compliance standards for example) it should be installed in line with the positive leg of the DC output wiring as shown below. Use a maximum 10A, time delay fuse. Note: Teknic IPC power supplies are not internally fused on the DC output side.

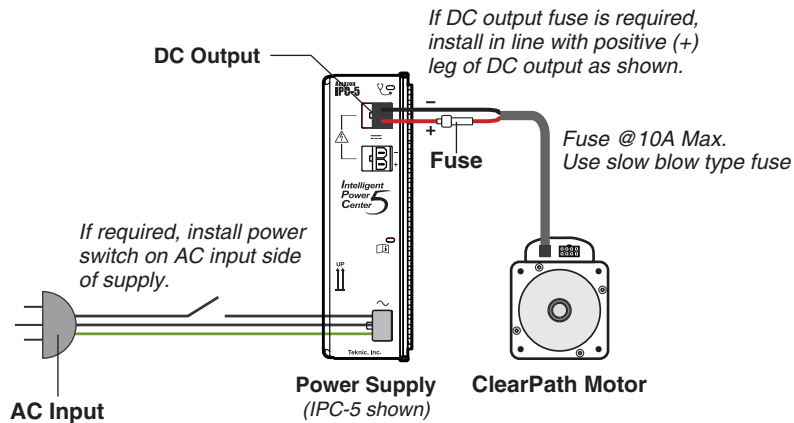

Power supply switching and fusing detail

SAFETY DISCONNECT CONTACTOR

A power disconnect contactor may be placed on the AC input side to satisfy safety system requirements.

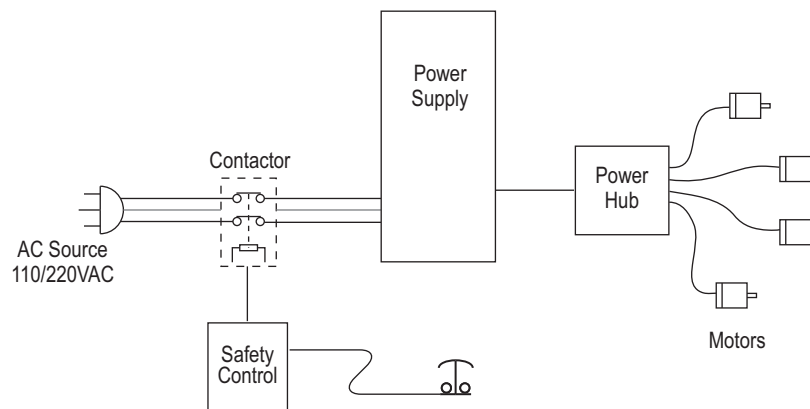

Safety disconnect contactor

IPC-3 AND IPC-5 THERMAL DERATING DATA

Operating an IPC power supply and a Power4-Hub above the recommended ambient temperatures (40C) will result in reduced power output.

If you are operating these components above 40C, refer to the IPC-3/5 Power Supply Manual for power derating information.

HOW TO MAKE AN INEXPENSIVE 24V LOGIC SUPPLY CABLE

All ClearPath-IP systems require a 24VDC supply for the SC Hub and for the POWER4-HUB (if used). The 24VDC cable must be terminated with a 2-pin Molex connector. This appendix shows a quick, inexpensive way to make a cable for use with a 24VDC supply with no crimping involved.

1. Start by acquiring a 24VDC power supply. A unit with screw terminals is easiest to wire, but almost any type of supply will do. A 1.5 amp supply will generally suffice for smaller systems (4 axes or less), but the *actual minimum current rating depends on the current draw of all devices attached to the supply (sensors, brakes, etc.)*.
2. Order a Teknic **CPM-CABLE-M2P2P-120**. This is a 120" (10-ft.), 2-pin Molex to 2-pin Molex cable as shown below.

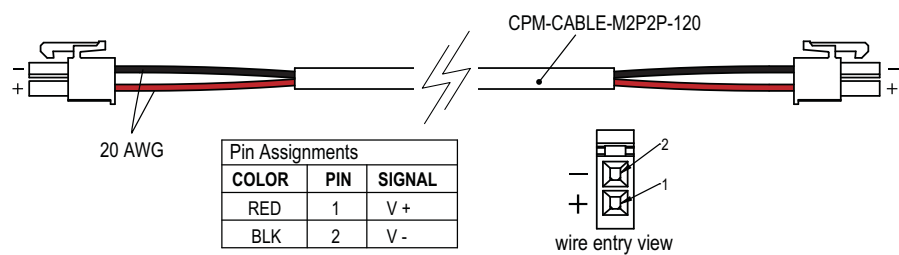

CPM-CABLE-M2P2P-120

3. Cut the cable to the desired length. If you cut it exactly in half, you can make two five foot long cables.
4. Strip the outer jacket and conductors on the unterminated end of the cable to create flying leads.
5. Connect the flying leads to your 24VDC supply. Insulate any exposed conductors with heat shrinkable tubing, electrical tape or similar.
6. **Test DC output polarity before connecting.** Use a DMM to verify proper polarity at the DC output connector. Use the above diagram as a reference.

OTHER PRODUCT NOTES

RE: ELECTRICAL FAST TRANSIENT (EFT) TESTING

Electrical fast transient testing might induce a motor communication error. In such an event, the motor will come to a controlled stop. The communication error can be cleared by a node reset, after which motion can be resumed on command.

CLEARPATH EMC INSTRUCTIONS

ClearPath motors can meet EMC requirements as defined in IEC 61326-1. In general, ClearPath motors are electrically quiet and immune devices; however, certain machine design factors can affect motor-related RF

emissions and immunity. These factors include cable routing, motor mounting, grounding practices, number of motors running simultaneously, and how aggressively the commanded moves are.

The recommendations in this document (see link below) will help machine manufacturers achieve IEC 61326-1 compliance.

<https://tekninc.com/files/downloads/ClearPath EMC Instructions.pdf>

Teknic, Incorporated
7650 Omnitech Pl
Victor, NY 14564

© 2025 Teknic, Inc. All rights reserved.
EtherNet/IP™ is a trademark of ODVA, Inc.