

Teknic ClearPath[®]

Fractional HP, DC Input

NEMA 34

- All dimensions are in inch [mm] unless otherwise noted.
- Sheet Scale 1:1.5
- Undimensioned features are per 3D file for model of interest for reference use.
- Unless otherwise specified untoleranced dimensions are nonbasic and default to:

X.XX: ± .010" [0.25mm]
 X.XXX: ± .005" [0.125mm]
 Angles: ± 1°

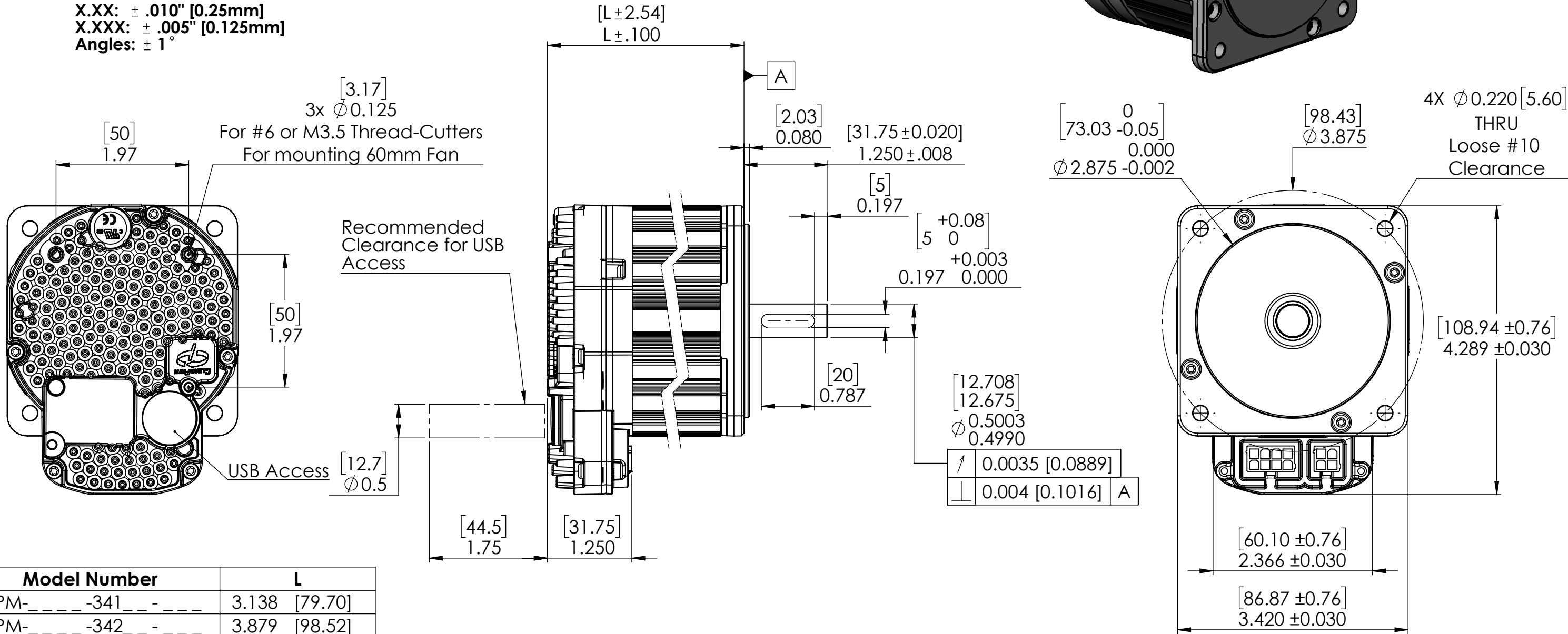

Model Number	L
CPM- -341 - - - -	3.138 [79.70]
CPM- -342 - - - -	3.879 [98.52]
CPM- -343 - - - -	4.627 [117.52]
CPM- -344 - - - -	5.382 [136.70]

Teknic, Incorporated
 Victor, NY 14564 USA

This document and related electronic files are the sole property of Teknic, Incorporated and contain proprietary information.

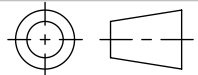
 Third-Angle Projection
 Interpret Geometric Tolerances per ANSI/ASME Y14.5 (2009)

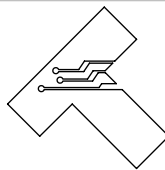

Additional documentation including product specifications, up-to-date compliance information, and manuals can be downloaded from Teknic's website.
 Visit <https://www.teknic.com/> to access that documentation.

DWG. NO./REV
 D1170/H

TITLE: 34xx ClearPath Motor Family